

Cummins **Onan**



Installation Manual

Commercial Mobile Generator Set

HGJAD (Spec J)

HGJAE (Spec J-K)

California

Proposition 65 Warning

Diesel engine exhaust and some of its constituents are known to the State of California to cause cancer, birth defects, and other reproductive harm.

Table of Contents

1. IMPORTANT SAFETY INSTRUCTIONS	1
1.1 Overview	1
1.2 Warning, Caution, and Note Styles Used In This Manual	1
1.3 General Safety Precautions	1
1.4 Automatic Generator Start Control Hazards	3
1.5 Electrical Shock and Arc Flash Can Cause Severe Personal Injury or Death	3
1.6 Generator Voltage Is Deadly	3
1.7 Engine Exhaust/Carbon Monoxide Is Deadly	4
1.8 Fuel Is Flammable and Explosive	5
1.9 Battery Gas Is Explosive	5
1.10 Moving Parts Can Cause Severe Personal Injury or Death	5
1.11 CARB	6
2. INTRODUCTION	7
2.1 About This Manual	7
2.2 Related Literature	7
2.3 Installation Codes and Standards for Safety	8
2.4 Electromagnetic Compatibility Compliance	9
2.5 Specifications	9
2.5.1 Gasoline Model Specifications	9
2.5.2 LPG Model Specifications	10
2.6 List of Acronyms	12
3. LOCATION, MOUNTING, AND VENTILATION	15
3.1 Location	15
3.1.1 Typical Generator Set Locations - Commercial Vehicle	16
3.1.2 Typical Generator Set Locations - High Mount	16
3.2 Mounting	16
3.2.1 Below Floor Mounting	17
3.2.2 Insulating Materials	17
3.2.3 Fire and Exhaust Barriers	17
3.3 Ventilation	17
4. EXHAUST CONNECTIONS	19
4.1 Tailpipe Installation	19
5. FUEL CONNECTIONS	25
5.1 Gasoline Motorized	25
5.1.1 Fuel Hoses	26
5.1.2 Fuel Lines	27
5.1.3 Routing Fuel Lines	27
5.2 Gasoline Nonmotorized (Evap)	28
5.2.1 Fuel Hoses	30

5.2.2 Fuel Lines.....	30
5.2.3 Routing Fuel Lines	31
5.2.4 Vapor and Fuel Return Line Requirements	31
5.2.5 Fuel Tank	31
5.2.6 Carbon Canister	32
5.2.7 Generator Set.....	33
5.3 Gasoline (EFI).....	33
5.3.1 Fuel Hoses.....	35
5.3.2 Fuel Lines.....	35
5.3.3 Routing Fuel Lines	36
5.3.4 Vapor and Fuel Return Line Requirements	36
5.3.5 Fuel Tank	36
5.3.6 Carbon Canister	37
5.3.7 Remote Fuel Pump Kit.....	38
5.3.8 Fuel Supply Line Pump to Generator Set.....	39
5.3.9 Generator Set.....	40
5.4 LPG.....	40
6. ELECTRICAL CONNECTIONS.....	45
6.1 AC Power Output Connections.....	45
6.1.1 Wiring Methods	46
6.1.2 Connecting to Shore Power	46
6.2 Remote Control Connections.....	48
6.3 Starting Battery Connections	49
6.3.1 Battery Compartment.....	49
6.3.2 Battery Cable Sizes	50
6.3.3 Battery Cables.....	50
6.3.4 Battery Cable Connections at the Generator Set	52
6.3.5 Generator Set (Equipment) Grounding Screw	52
7. INSTALLATION REVIEW AND STARTUP	53
7.1 Installation Review	53
7.2 Startup	53
7.3 Hot Air Recirculation Test.....	54
7.3.1 Test Method	54
7.3.2 Test Requirement.....	55
APPENDIX A. OUTLINE DRAWINGS	57
A.0 HGJAD/HGJAE Outline Drawing	59

1 Important Safety Instructions

1.1 Overview

Thoroughly read the Operator Manual before operating the generator set. It contains important instructions that should be followed during operation and maintenance. Safe operation and top performance can only be achieved when equipment is properly operated and maintained. The owners and operators of the generator set are solely responsible for its safe operation.

Generator set operation, maintenance, and installation must comply with all applicable local, state, and federal codes and regulations. Electricity, fuel, exhaust, moving parts, and batteries present hazards which can result in severe personal injury or death. Only trained and experienced personnel with knowledge of fuels, electricity, and machinery hazards should perform generator set installation or adjustment procedures; or remove, dismantle, or dispose of the generator set.

Save these instructions.

1.2 Warning, Caution, and Note Styles Used In This Manual

The following safety styles and symbols found throughout this manual indicate potentially hazardous conditions to the operator, service personnel, or the equipment.

⚠ DANGER
<i>Indicates a hazardous situation that, if not avoided, will result in death or serious injury.</i>

⚠ WARNING
<i>Indicates a hazardous situation that, if not avoided, could result in death or serious injury.</i>

⚠ CAUTION
<i>Indicates a hazardous situation that, if not avoided, could result in minor or moderate injury.</i>

NOTICE
Indicates information considered important, but not hazard-related (e.g., messages relating to property damage).

1.3 General Safety Precautions

⚠ WARNING
<i>Operation of equipment is unsafe when mentally or physically fatigued. Do not operate equipment in this condition, or after consuming any alcohol or drug.</i>

⚠ WARNING

Maintaining or installing a generator set can cause severe personal injury. Wear personal protective equipment such as safety glasses, protective gloves, hard hats, steel-toed boots, and protective clothing when working on equipment.

⚠ WARNING

Running the generator set without the cover or service door can cause severe personal injury or equipment damage. Do not operate the generator set with the cover or service doors removed.

⚠ WARNING

Starting fluids, such as ether, can cause explosion and generator set engine damage. Do not use.

⚠ WARNING

Benzene, found in some fuels, has been identified by some state and federal agencies to cause cancer or reproductive toxicity. Do not ingest, breathe the fumes, or contact gasoline when checking, draining, or adding gasoline.

⚠ WARNING

Used engine oils have been identified by some state and federal agencies to cause cancer or reproductive toxicity. Do not ingest, breathe the fumes, or contact used oil when checking or changing engine oil.

⚠ CAUTION

To prevent accidental or remote starting while working on the generator set, disconnect the negative (-) battery cable at the battery using an insulated wrench.

⚠ CAUTION

Unsecured or loose fasteners can cause equipment damage. Make sure all fasteners are secure and properly torqued.

⚠ CAUTION

Oily rags and other material can cause fire and restrict cooling. Keep the generator set, drip pan, and compartment clean.

⚠ CAUTION

Accumulated grease and oil can cause overheating and engine damage presenting a potential fire hazard. Keep the generator set clean and repair any oil leaks promptly.

NOTICE

Keep multi-class ABC fire extinguishers handy. Class A fires involve ordinary combustible materials such as wood and cloth. Class B fires involve combustible and flammable liquid fuels and gaseous fuels. Class C fires involve live electrical equipment. (Refer to NFPA No. 10 in applicable region.)

1.4 Automatic Generator Start Control Hazards

WARNING

Accidental starting can cause severe personal injury or death. Turn off the AGS whenever performing maintenance or service, when the vehicle is stored between uses, is awaiting service, or is parked in a garage or other confined area.

Unexpected starting may occur if the generator set is equipped with an inverter-charger or other Automatic Generator Start (AGS) control. This may cause exposure to:

- Unexpected generator starting
- Moving parts hazards
- Electric shock
- Exhaust carbon monoxide (CO)

1.5 Electrical Shock and Arc Flash Can Cause Severe Personal Injury or Death

WARNING

Electrical shocks and arc flashes can cause severe personal injury or death. Adhere to the following guidelines:

- *Only qualified service personnel certified and authorized to work on power circuits should work on exposed energized power circuits.*
- *All relevant service material must be available for any electrical work performed by certified service personnel.*
- *Exposure to energized power circuits with potentials of 50 VAC or 75 VDC or higher poses a significant risk of electrical shock and electrical arc flash.*
- *Refer to standard NFPA 70E, or equivalent safety standards in corresponding regions, for details of the dangers involved and for safety requirements.*

1.6 Generator Voltage Is Deadly

WARNING

Improperly connected generator electrical output connections can cause equipment damage, severe personal injury, or death. Electrical connections must be made by a trained and experienced electrician in accordance with applicable codes.

WARNING

Improper installations can cause equipment damage, severe personal injury, or death. All installations must be conducted by trained and experienced personnel in accordance with the installation instructions and all applicable codes.

WARNING

Back feed to shore power can cause electrocution and damage to equipment. The generator set must not be connected to shore power or to any other source of electrical power. An approved switching device must be used to prevent interconnections.

⚠ WARNING

Live electrical equipment can cause electrocution. Use caution when working on live electrical equipment. Remove jewelry, make sure clothing and shoes are dry, stand on a dry wooden platform or rubber insulating mat, and use tools with insulated handles.

1.7 Engine Exhaust/Carbon Monoxide Is Deadly

⚠ WARNING

Substances in exhaust gases have been identified by some state and federal agencies to cause cancer or reproductive toxicity. Do not breathe in or come into contact with exhaust gases.

⚠ WARNING

Carbon monoxide is a poisonous gas. Inhalation of this gas can cause severe personal injury or death. Adhere to the following bullet points to make sure carbon monoxide is not being inhaled by occupants of the vehicle as well as others working on or around the generator set.

- ***Inspect for exhaust leaks, and test and confirm that all carbon monoxide detectors are working in accordance with the manufacturer's instructions or owner's manual, prior to every startup, and after every 8 hours of running.***
- ***Never occupy the vehicle while the generator set is running unless the vehicle is equipped with a working carbon monoxide detector.***
- ***Never operate the generator set when the vehicle is in a confined space, such as a garage, basement, or building of any kind.***
- ***Make sure the exhaust system is installed in accordance with the generator set installation manual.***
- ***Never use engine cooling air for heating a working or living space compartment.***

Carbon Monoxide (CO) is odorless, colorless, tasteless, and non-irritating. It cannot be seen or smelled. Exposure, even to low levels of CO for a prolonged period can lead to asphyxiation (lack of oxygen).

Mild effects of CO poisoning include:

- headache
- dizziness
- drowsiness
- fatigue
- chest pain
- confusion

More extreme symptoms include:

- vomiting
- seizure
- loss of consciousness

1.8 Fuel Is Flammable and Explosive

WARNING

Fuel and fuel vapor is highly explosive. Adhere to the following bullets to avoid igniting fuel and fuel vapors.

- *Do not smoke or turn electrical switches on or off where fuel fumes are present or in areas sharing ventilation with fuel tanks or equipment.*
- *Keep flame, sparks, pilot lights, arc-producing equipment and all other sources of ignition well away from fuel lines and sources.*
- *Fuel lines must be secured, free of leaks, and separated or shielded from electrical wiring.*

Leaks can lead to explosive accumulations of gas.

- LPG sinks when released and can accumulate inside housings and basements and other below-grade spaces.

NOTICE

Natural gas is identifiable by a rotten egg smell.

1.9 Battery Gas Is Explosive

WARNING

Battery gas is highly explosive and may cause personal injury or death if ignited. Take the proper precautions to avoid personal injury.

- *For personal safety, wear appropriate PPE when working on or around the generator set.*
- *To make sure battery gas is not ignited, do not smoke around the generator set.*
- *To reduce arcing when disconnecting or reconnecting battery cables, always disconnect the negative (-) battery cable first and reconnect it last.*

1.10 Moving Parts Can Cause Severe Personal Injury or Death

WARNING

Moving parts can cause severe personal injury or death, and hot exhaust parts can cause severe burns. Make sure all protective guards are properly in place before starting the generator set.

WARNING

Hot moving, and electrically live parts can cause severe personal injury or death. Keep children away from the generator set.

⚠ WARNING

Hot, moving, and electrically live parts can cause severe personal injury or death. Only trained and experienced personnel should make adjustments while the generator set is running.

⚠ WARNING

Moving parts can catch on loose items such as clothing or jewelry. Do not wear loose clothing or jewelry near moving parts such as PTO (power take-off) shafts, fans, belts, and pulleys.

⚠ WARNING

Moving parts can entangle appendages such as fingers. Keep the protective guards in place over fans, belts, pulleys, and other moving parts and keep hands away from all moving parts.

1.11 CARB

⚠ CAUTION

Unauthorized modifications or replacement of fuel, exhaust, air intake, or speed control system components that affect engine emissions are prohibited by law in the state of California.

2 Introduction

2.1 About This Manual

This manual is a guide for the installation of the generator sets listed on the front cover. Proper installation is essential for top performance. Read through this manual before starting the installation. Leave this manual in the vehicle.

The installer must be qualified to perform installation of electrical and mechanical equipment.

This manual addresses the following aspects of the installation:

- Location, Mounting, and Ventilation
- Exhaust Connections
- Fuel Connections
- Electrical Connections
- Startup

See the Operator Manual for operation and maintenance and the Service Manual for service.

The information contained within the manual is based on information available at the time of going to print. In line with Cummins Power Generation policy of continuous development and improvement, information may change at any time without notice. The users should therefore make sure that before commencing any work, they have the latest information available. The latest version of this manual is available on QuickServe Online (<https://qsol.cummins.com/info/index.html>).

2.2 Related Literature

Before any attempt is made to operate the generator set, the operator should take time to read all of the manuals supplied with the generator set, and to familiarize themselves with the warnings and operating procedures.

CAUTION

A generator set must be operated and maintained properly if you are to expect safe and reliable operation. The Operator manual includes a maintenance schedule and a troubleshooting guide. The Health and Safety manual must be read in conjunction with this manual for the safe operation of the generator set:

- Health and Safety Manual (0908-0110)

The relevant manuals appropriate to your generator set are also available, the documents below are in English:

- Operator Manual for Commercial Mobile Generator Set HGJAD (Spec J) and HGJAE (Spec J-K) (A035D007)
- Installation Manual for Commercial Mobile Generator Set HGJAD (Spec J) and HGJAE (Spec J-K) (A035D003)

- Generator Set Service Manual for Commercial Mobile Generator Set HGJAD (Spec J) and HGJAE (Spec J-K) (A035D011)
- Recommended Spares List (RSL) for Commercial Mobile Generator Set HGJAD (Spec J) and HGJAE (Spec J-K) (A041X686)
- Parts Manual for Commercial Mobile Generator Set HGJAD (Spec J) and HGJAE (Spec J-K) (0983-0202)
- Standard Repair Times - AR Family (0900-0617)
- Service Tool Manual (A043D529)
- Failure Code Manual (F1115C)
- Warranty Manual (A040W374)
- Global Commercial Warranty Statement (A028U870)

2.3 Installation Codes and Standards for Safety

⚠ CAUTION

The Commercial Generator Set Warranty applies only when the generator set is installed in a commercial or recreational vehicle. The RV Generator Set Warranty applies only when the generator set is installed in a recreational vehicle.

The installer bears sole responsibility for the selection of the appropriate generator set, for its proper installation, and for obtaining approvals from the authorities (if any) having jurisdiction over the installation. The generator sets meet the basic requirements of the Standard for Safety for Engine Generator Sets for Recreational Vehicles, ANSI/RVIA EGS-1 and are suitable for installation in accordance with:

- ANSI A1192 (NFPA No. 501C)—Recreational Vehicles
- NFPA No. 70, Article 551—Recreational Vehicles and RV Parks
- CSA Electrical Bulletin 946—Requirements for Internal Combustion Engine-Driven Electric Generators for Use in Recreational Vehicles

Federal, state, and local codes, such as the California Administrative Code—Title 25 (RV installation), might also be applicable. Installation codes and recommendations can change from time-to-time and are different in different countries, states, and municipalities. Obtain the standards listed in the table below for reference.

TABLE 1. REFERENCE CODES AND STANDARDS

Code of Federal Regulations, Title 49: Chapter III and Chapter V	Superintendent of Documents P. O. Box 371954 Pittsburgh, PA 15250-7954
NFPA 58, 70, 1192	National Fire Protection Association 470 Atlantic Avenue Boston, MA 02210
ANSI/RVIA-EGS-1	Recreational Vehicle Industry Association 14650 Lee Road Chantilly, VA 22021

California Administrative Code—Title 25, Chapter 3	State of California Documents Section P.O. Box 1015 North Highlands, CA 95660
CAN/CSA-Z240 Recreational Vehicles Bulletin 946	Canadian Standards Association Housing and Construction Materials Section 178 Rexdale Blvd. Rexdale, Ontario, Canada M9W 1R3
SAE J1231, J1508, J2044, J2599	SAE World Headquarters 400 Commonwealth Drive Warrendale, PA 15096

2.4 Electromagnetic Compatibility Compliance

Generator sets emit and receive electromagnetic (radio frequency) energy. If the generator set affects operation of nearby devices, or nearby devices affect generator set operation, increase the distance between them.

When used in countries where compliance to the EMC directive is required: This generator set has been evaluated for use in the residential, commercial, and light industrial environments.

2.5 Specifications

2.5.1 Gasoline Model Specifications

TABLE 2. GASOLINE MODEL SPECIFICATIONS

	7.0 HGJAD	7.0 HGJAE	5.5 HGJAD	5.5 HGJAE
GENERATOR: 2-Pole Revolving Field, Self-Excited, 1-Phase, Capped Digital Voltage Regulated, 2-Bearing, Vertical Shaft				
Power	7000 Watts		5500 Watts	
Frequency ¹	60 Hz		60 Hz	
1-Ph, 4-Wire V/A	120/240 Volts, 29.2 Amps		120/240 Volts, 22.9 Amps	
1-Ph, 2-Wire V/A	120 Volts, 58.3 Amps		120 Volts, 45.8 Amps	
3-Ph V/A	120/240 Volts, 16.8 Amps		120/240 Volts, 12 Amps	
Speed	3600 RPM		3600 RPM	
FUEL CONSUMPTION:				
No Load	1.6 l/h (0.43 gph)		1.3 l/h (0.34 gph)	1.3 l/h (0.35 gph)
Half Load	2.7 l/h (0.70 gph)	2.8 l/h (0.73 gph)	2.2 l/h (0.58 gph)	2.3 l/h (0.60 gph)
Full Load	4.3 l/h (1.13 gph)	4.6 l/h (1.22 gph)	3.4 l/h (0.89 gph)	3.6 l/h (0.95 gph)
ENGINE: 90° V-Twin Cylinder, 4-Cycle, Spark Ignited, OHV, Air-Cooled, Vertical Shaft				
Bore	80 mm (3.15 in)			
Stroke	65 mm (2.56 in)			
Displacement	653 cm ³ (39.8 in ³)			
Compression Ratio	8.0 : 1			

	7.0 HGJAD	7.0 HGJAE	5.5 HGJAD	5.5 HGJAE
Oil Capacity	1.8 liters (2.0 qt)			
Intake Valve Lash (Cold)	0.10 mm (0.004 in)			
Exhaust Valve Lash (Cold)	0.10 mm (0.004 in)			
Spark Plug Gap	6-7 mm (0.025 in)			
Spark Plug Torque	23-32 Nm (18-25 ft-lbs)			
Ignition Timing	20° BTDC, non-adjustable			
Magneto Air Gap	0.3 mm (0.012 in)			
Compression	3.9 kgf/cm ² (55.47 lbf/in ²) @ 500 RPM			
DC SYSTEM:				
Battery Voltage	12 Volts			
Minimum Battery Rating	450 CCA @ -18 °C (0 °F)			
INSTALLATION:				
Exhaust O. D.	31.75 mm (1.25 in)			
Fuel Supply Connection	5/16 inch SAE J1231 Type 1	1/4 inch SAE J1231 Type 1	5/16 inch SAE J1231 Type 1	1/4 inch SAE J1231 Type 1
Fuel Return Connection	5/16 inch SAE J1231 Type 1	-	5/16 inch SAE J1231 Type 1	-
Minimum Free Air Inlet Area	232 cm ² (36 in ²)			
Weight	136 kg (299 lb)		131 kg (288 lb)	
Minimum Compartment Size (H x D x W) ²	438 mm x 589 mm x 879 mm (17.2 in x 23.2 in x 34.6 in)			
1. 60 Hz models are listed by CSA and the US Testing Company.				
2. See the Installation Manual for additional considerations when sizing the generator set compartment.				

2.5.2 LPG Model Specifications

TABLE 3. LPG MODEL SPECIFICATIONS

	6.5 HGJAE	5.5 HGJAE
GENERATOR: 2-Pole Revolving Field, Self-Excited, 1-Phase, Capped Digital Voltage Regulated, 2-Bearing, Vertical Shaft		
Power	6500 Watts	5500 Watts
Frequency ¹	60 Hz	60 Hz
Voltage	120/240 Volts	120/240 Volts
Current	27 Amps	22.9 Amps
Speed	3600 RPM	3600 RPM
FUEL CONSUMPTION:		

	6.5 HGJAE	5.5 HGJAE
No Load	1.0 kg/h (2.2 lbs/h)	0.8 kg/h (1.8 lbs/h)
Half Load	1.8 kg/h (3.9 lbs/h)	1.5 kg/h (3.3 lbs/h)
Full Load	2.4 kg/h (5.3 lbs/h)	2.1 kg/h (4.6 lbs/h)
ENGINE: 90° V-Twin Cylinder, 4-Cycle, Spark Ignited, OHV, Air-Cooled, Vertical Shaft		
Bore	80 mm (3.5 in)	
Stroke	65 mm (2.56 in)	
Displacement	653 cm ³ (39.8 in ³)	
Compression Ratio	8.0 : 1	
Oil Capacity	1.8 liters (2.0 qt)	
Intake Valve Lash (Cold)	0.10 mm (0.004 in)	
Exhaust Valve Lash (Cold)	0.10 mm (0.004 in)	
Spark Plug Gap	6-7 mm (0.025 in)	
Spark Plug Torque	23-32 Nm (18-25 ft-lbs)	
Ignition Timing	20° BTDC, non-adjustable	
Magneto Air Gap	0.3 mm (0.012 in)	
Compression	3.9 kgf/cm ² (55.47 lbf/in ²) @ 500 RPM	
DC SYSTEM:		
Battery Voltage	12 Volts	
Minimum Battery Rating	450 CCA @ -18 °C (0 °F)	
INSTALLATION:		
Exhaust O. D.	31.75 mm (1.25 in)	
Minimum Free Air Inlet Area	232 cm ² (36 in ²)	
LPG Vapor Connection Pressure	3/8-18 NPTF 228–330 mm (9–13 in) WC	
LPG Liquid Connection Pressure	1/4-18 NPTF Tank Pressure	
Weight	136 kg (299 lb)	131 kg (288 lbs)
Minimum Compartment Size (H x D x W) ²	HGJAD/HGJAE: 438 mm x 589 mm x 879 mm (17.2 in x 23.2 in x 34.6 in)	
1. 60 Hz models are listed by CSA and the US Testing Company. 2. See the Installation Manual for additional considerations when sizing the generator set compartment.		

2.6 List of Acronyms

TABLE 4. ACRONYM DEFINITIONS

Acronym	Definition
AC	Alternating Current
AGS	Automatic Generator Start
AISI	American Iron and Steel Institute
ANSI	American National Standards Institute
API	American Petroleum Institute
ASTM	American Society for Testing and Materials (now known as ASTM International)
BS	Build Standard
BTDC	Before Top Dead Center
CARB	California Air Resources Board
CCA	Cold Cranking Amp
CFR	Code of Federal Regulations
CNG	Compressed Natural Gas
CO	Carbon Monoxide
CPG	Cummins Power Generation
CSA	Canadian Standards Association
DC	Direct Current
EEPROM	Electrically Erasable Programmable Read Only Memory
EGT	Exhaust Gas Temperature
EMC	Electromagnetic Compatibility
EPA	Environmental Protection Agency
GFCI	Grounded Fault Circuit Interrupters
hp	High Pressure
I.D.	Inside Diameter
ISO	International Organization for Standardization
LED	Light-emitting Diode
LPG	Liquid Petroleum Gas
MAP	Manifold Air Pressure
MAT	Manifold Air Temperature
NFPA	National Fire Protection Agency
NG	Natural Gas
NPTF	National Pipe Taper Fuel
O.D.	Outside Diameter
OEM	Original Equipment Manufacturer
PPE	Personal Protective Equipment

Acronym	Definition
PTO	Power Take-Off
RAM	Random Access Memory
ROM	Read Only Memory
RV	Recreational Vehicle
RVIA	RV Industry Association
SAE	Society of Automotive Engineers
UNC	Unified National Coarse
US, U.S.	United States
WC	Water Column

TABLE 5. ACRONYMS FOR UNITS OF MEASUREMENT

Acronym	Definition
Amp	Ampere
C	Celsius
cm	centimeter
D	Depth
F	Fahrenheit
ft	Feet, foot
ft-lbs	Foot-pounds
g	gram
gph	Gallons per hour
H	Height
Hz	Hertz
in	Inch
kg	kilogram
kg/h	kilograms per hour
kgf/cm ²	kilogram-force per square centimeter
kW	kilowatt
l/h	Liters per hour
lb	Pound
lbf/in ² OR psi	Pound per square inch
lbs/h	Pounds per hour
m	Meter
mm	millimeter
Nm	Newton meter
psi OR lbf/in ²	Pound per square inch
qt	Quart

Acronym	Definition
RPM	Revolutions per Minute
VAC	Volts Alternating Current
VDC	Volts Direct Current
W	Watts, Width

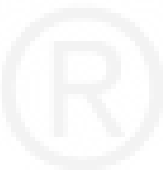

3 Location, Mounting, and Ventilation

The location, mounting, and ventilation of a generator set must be such that mounting is secure, engine exhaust and fuel vapors are prevented from entering the vehicle, rain and road debris are prevented from entering the generator set, and ready access is afforded for operating the generator set and performing periodic maintenance.

3.1 Location

Typical locations for generator set installation are shown below.

The location must provide:

- Ready access for starting and stopping the generator set and performing all periodic maintenance.
- Separation from sources of flammable vapors, such as batteries and fuel tanks, which the generator set could ignite.
- Access for connecting and disconnecting fuel lines, battery cables, remote control wiring, and AC wiring.
- Access from below for draining engine oil and changing the oil filter.
- Unobstructed space below the generator set for proper cooling air flow.
- The generator set must not share a compartment or ventilation with batteries or fuel tanks. An operating generator set can ignite flammable vapors. Make sure the space below the generator set cooling outlet is unobstructed for at least 305 mm (12 in) and open on at least 3 sides.
- Locate or shield the generator set cooling air openings from direct rain, road splash and debris thrown up by the road wheels.
- Space to mount the generator set with at least 12.7 mm (1/2 in) clearance at the top and any side of the generator set. Minimum clearances apply to any thermal or acoustic insulation with which a compartment may be lined.
- Locating a generator set more than 5 feet above the floor and at the very back of the vehicle can result in 'g' forces imparted to the generator set that causes physical damage to it as it travels down the road. Generator sets located in these areas do not have warranty coverage for damage resulting from high 'g' loads.

NOTICE

Consider air flow requirements for passenger side installations when the generator is required to operate while the vehicle is in motion. Installations must meet rise over ambient tests (see [Hot Air Recirculation Test](#)) in various modes of operation.

3.1.1 Typical Generator Set Locations - Commercial Vehicle

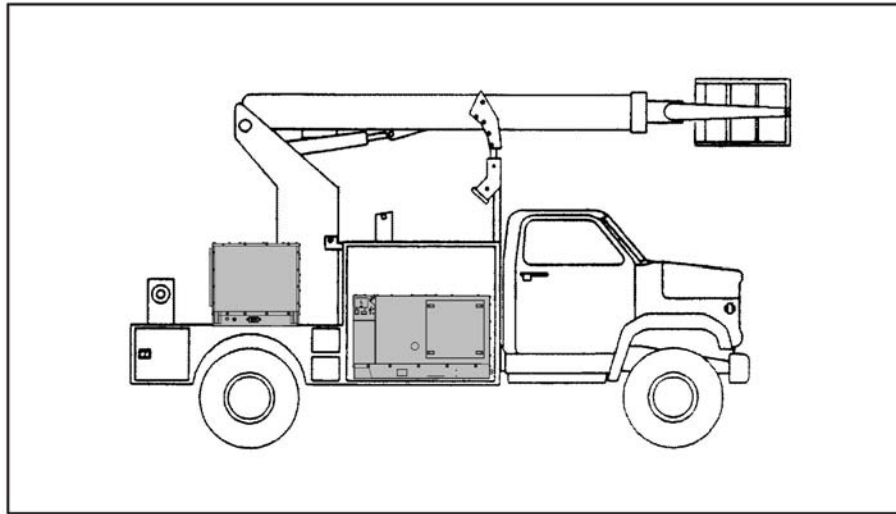

FIGURE 1. TYPICAL GENERATOR SET LOCATIONS - COMMERCIAL VEHICLE

3.1.2 Typical Generator Set Locations - High Mount

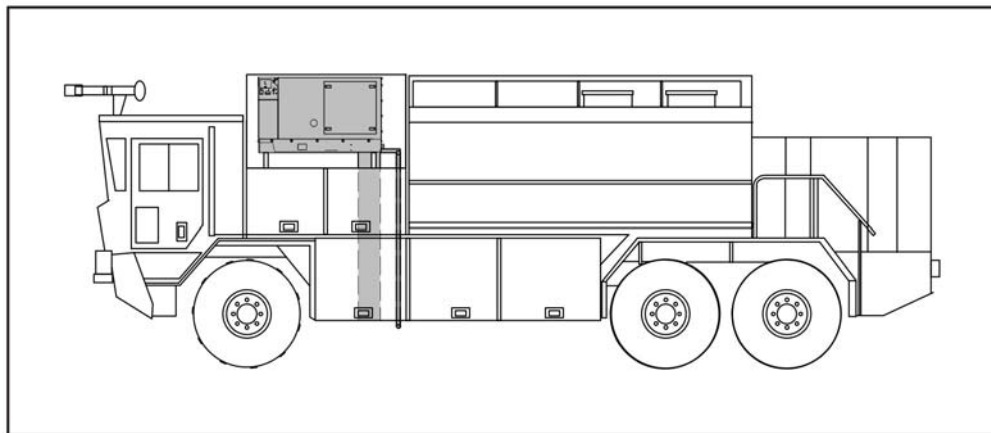

FIGURE 2. TYPICAL GENERATOR SET LOCATIONS - HIGH MOUNT

3.2 Mounting

⚠ WARNING

The generator set support structure must be designed and installed to support and restrain the dynamic weight of the generator set. Failure to do so can result in the generator set dropping onto the roadway causing property damage, severe personal injury, or death.

- Support the generator set on a structure able to resist the dynamic weight of the generator set: ± 3 g-force vertical and ± 1 g-force horizontal. See [Section 2.5 on page 9](#) for the weight of the generator set. See the outline drawings in [Appendix A on page 57](#) for mounting bolt hole locations.

TABLE 6. MOUNTING SCREWS

Quantity	Type	Torque
4	3/8 inch thread-forming bolts	42 Nm (31 ft-lbs)

3.2.1 Below Floor Mounting

Mounting kits are available for below floor mounting. Follow the instructions in the kit.

Do not mount the generator set within the approach or departure angles of the vehicle or below the axle line.

3.2.2 Insulating Materials

Acoustic/thermal insulation and adhesive must be classified as "Self-Extinguishing" at not less than 90 °C (200 °F). Do not line the bottom of a compartment with insulation since it absorbs fuel and oil.

3.2.3 Fire and Exhaust Barriers

⚠ WARNING

Exhaust gas and fire are deadly! Install a vapor-tight and fire-resistant barrier of approved materials between the generator set and the vehicle interior. Do not duct generator set cooling air into the vehicle for heating.

- Barriers to provide vapor and fire resistance must be installed between the generator set and the interior of the vehicle if the generator set is mounted below the floor.
- If the generator set is mounted in a compartment on the floor of the vehicle, the entire compartment must be lined with vapor and fire resistive materials.
- Use approved materials (26 gauge galvanized steel or equivalent). See NFPA 1192 for details.
- All seams and openings in the barriers for wiring, mounting screws, etc. must be sealed.

3.3 Ventilation

Generator set cooling air must not be obstructed.

- A free-air inlet size of at least 232 cm² (36 in²) is required. Grilles, louvers, and other kinds of decorative treatments for air openings are restrictive. Contact the manufacturer of the decorative assembly or material to find out how large of an opening is required to obtain the minimum free-air inlet size.
- Unless the compartment air inlet lines up directly with the generator set air inlet, a clearance of at least 50.8 mm (2 in) is required at the front of the generator set for air to get to the generator set inlet. Staggering a compartment side opening or pulling the air up under the skirt of the vehicle will reduce line-of-sight noise but requires the extra clearance in front.

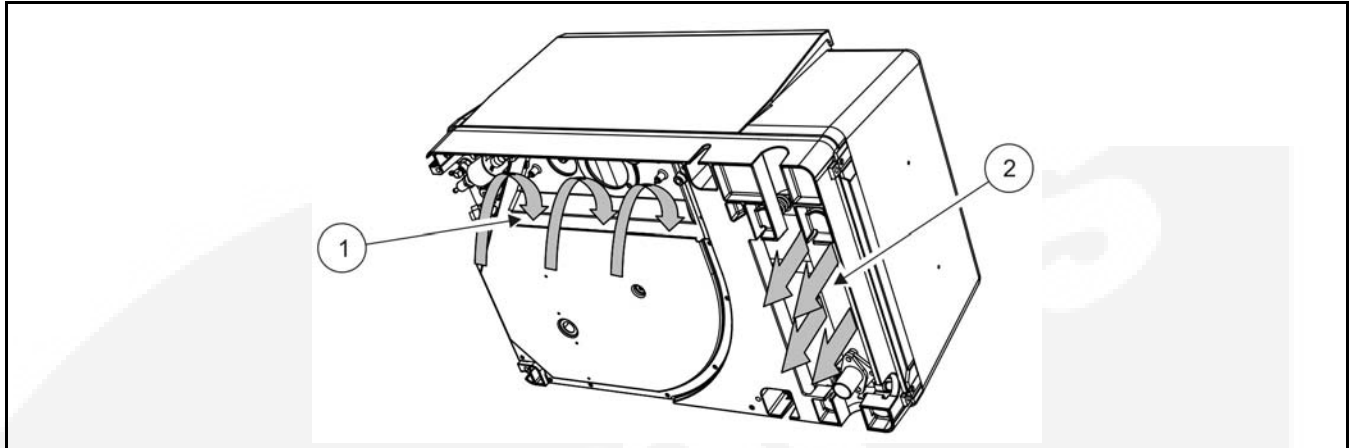

No.	Description
1	Air Inlet
2	Air Outlet

FIGURE 3. GENERATOR SET COOLING AIR INLET AND OUTLET

4 Exhaust Connections

⚠ WARNING

This product incorporates a catalyst exhaust system which leads to higher exhaust gas temperatures. The installer must review and follow all guidelines for the installation. Care must be taken to make sure that all installation requirements in this entire manual are met.

The generator set is equipped with a U.S. Forest Service approved spark-arrest muffler. Failure to provide and maintain a spark arrester can be a violation of the law. Liability for damage, injury, and warranty expense due to the modification of the exhaust system or the use of unapproved parts is the responsibility of the person performing the modification or installing the unapproved exhaust system parts.

⚠ WARNING

EXHAUST GAS IS DEADLY! To keep exhaust gases from entering the vehicle do not terminate the exhaust tailpipe underneath the vehicle or closer than 153 mm (6 in) to openings into the vehicle or route it such that it is not protected. Use approved materials only.
The tailpipe of the generator set will be hot during operation and can cause severe burns. To reduce the risk of contact, concentration must be used where the tailpipe will be located and routed.

The generator set exhaust system must be gas tight and designed to prevent entry of exhaust gasses into the vehicle interior.

4.1 Tailpipe Installation

The muffler is mounted inside the generator set and has a flange to which the tailpipe adapter (available from Cummins Onan) is bolted or a collar to which the tailpipe is clamped or a short adapter bolted to its outlet flange.

⚠ WARNING

Flexible pipe is not gas tight or durable and can cause exhaust gas leaks. Do not use flexible pipe for tailpipe.

1. Use 18-gauge 1-3/8 inch I.D. aluminized steel tubing or material of equivalent heat and corrosion resistance for the tailpipe.
2. Support a tailpipe longer than 457 mm (1-1/2 ft) near its end and at intervals of 900 mm (3 ft) or less. Use automotive-type tailpipe hangers. Do not attach the hangers to combustible material such as wood.
3. Use U-bolt muffler clamps to connect sections of tailpipe. Overlapping pipe should be slotted.
4. Do not route the tailpipe near fuel lines or fuel tanks.
5. Do not route the tailpipe closer than 76 mm (3 in) to combustible material (wood, felt, cotton, organic fibers, etc.) unless it is insulated or shielded. The temperature rise (above ambient) on adjacent combustible material must not exceed 65 °C (117 °F).
6. Do not route the exhaust tailpipe underneath the oil drain.

7. Do not route the exhaust tailpipe such that it will restrict the air inlet/outlet.
8. To keep the tailpipe from being damaged, do not route it such that it protrudes into the approach or departure angles of the vehicle or below the axle clearance line.
9. Do not interconnect generator set and vehicle engine exhaust systems.
10. Do not terminate the tailpipe underneath the vehicle. Extend it a minimum of 25 mm (1 in) beyond the perimeter of the vehicle. Support the end of the tailpipe such that it cannot be pushed in and up under the skirt of the vehicle.
11. Do not terminate the tailpipe such that it is closer than 153 mm (6 in) to any opening, such as a door, window, vent, or unsealed compartment into the vehicle interior.

⚠ CAUTION

Excessive back pressure can cause loss of performance and engine damage.

12. Make sure a tailpipe deflector will not cause excessive back pressure.

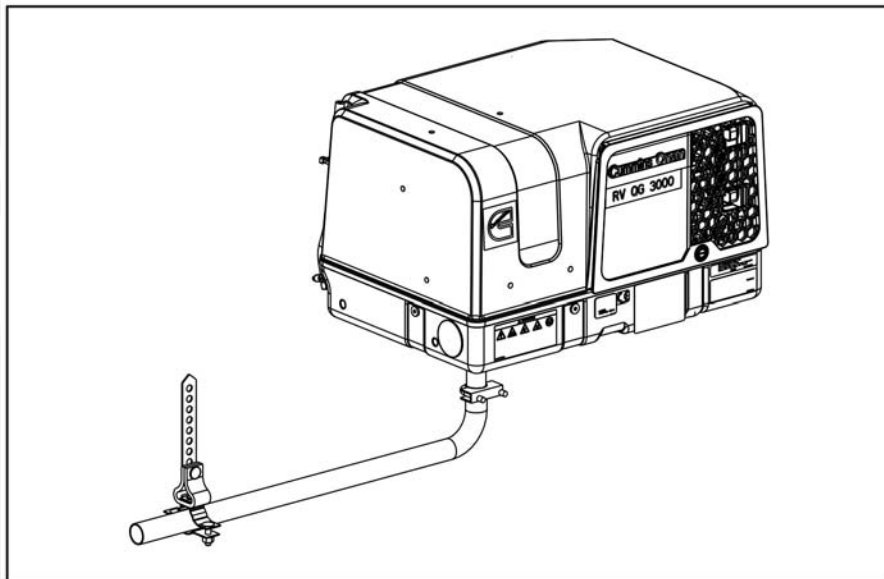

FIGURE 4. TYPICAL TAILPIPE INSTALLATION (BOTTOM OF UNIT)

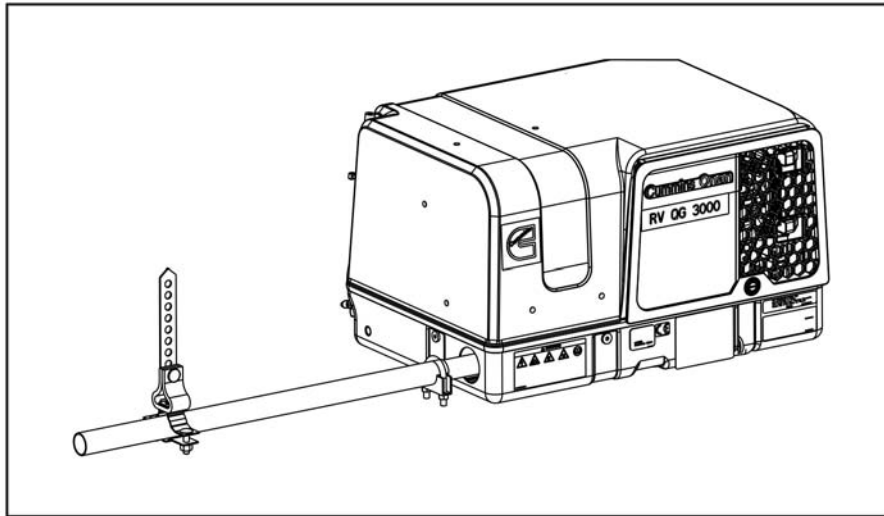

FIGURE 5. TYPICAL TAILPIPE INSTALLATION (SIDE OF UNIT)

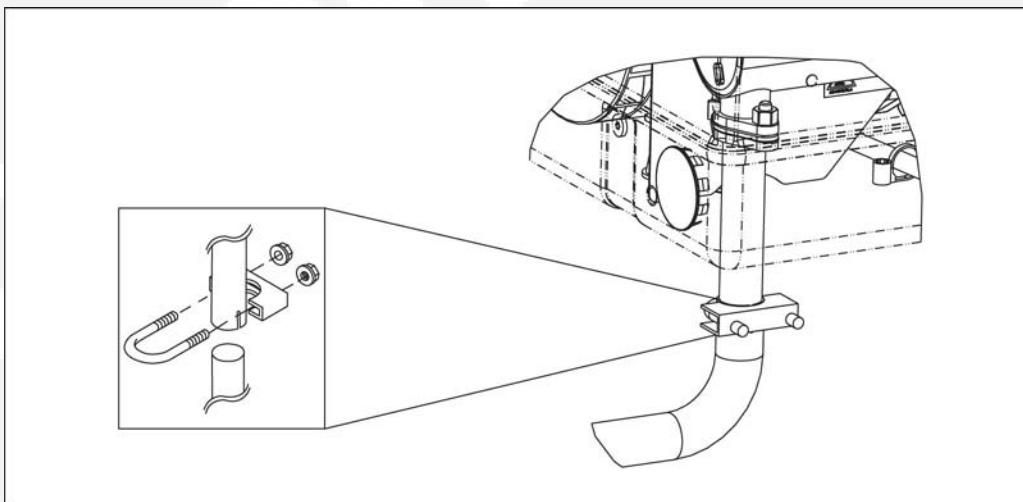

FIGURE 6. EXHAUST TAILPIPE CONNECTIONS

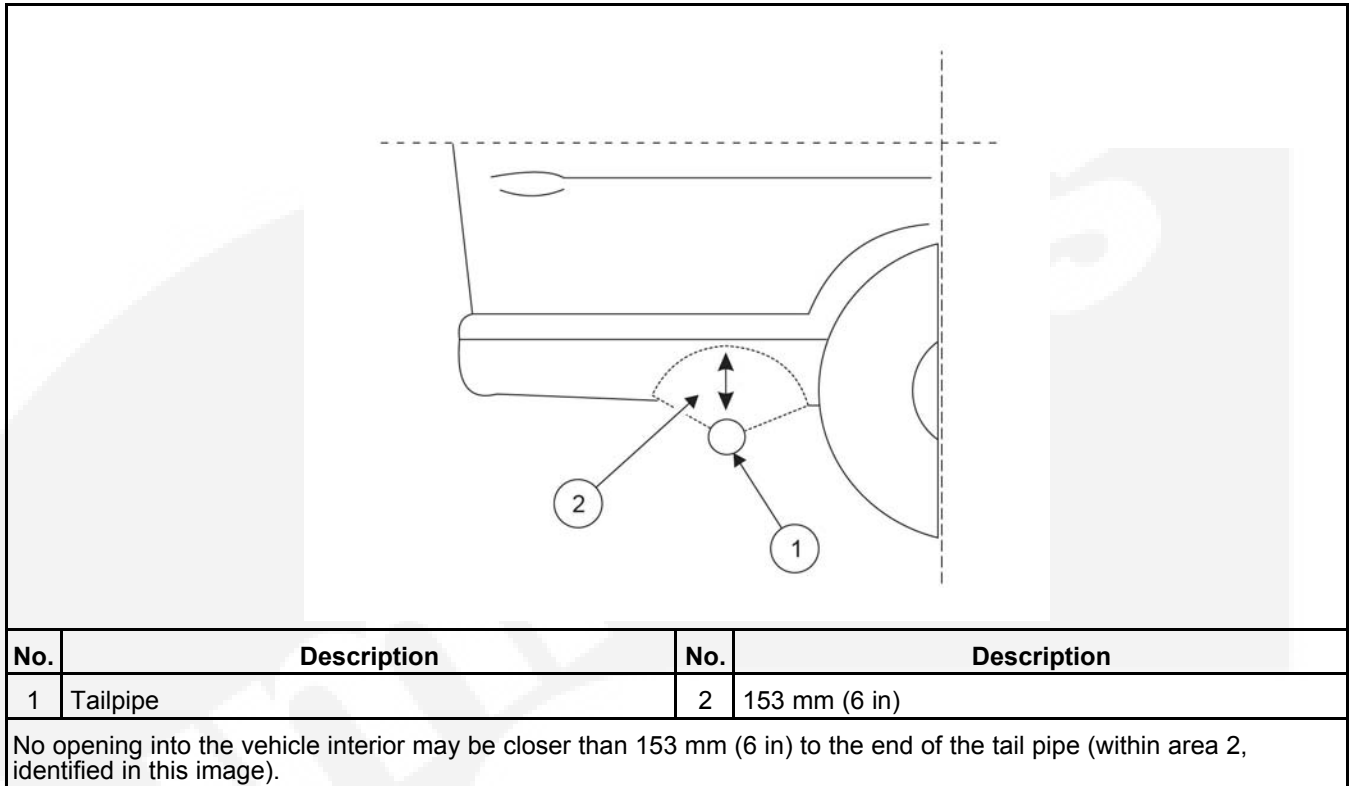

FIGURE 7. MINIMUM DISTANCES TO OPENINGS

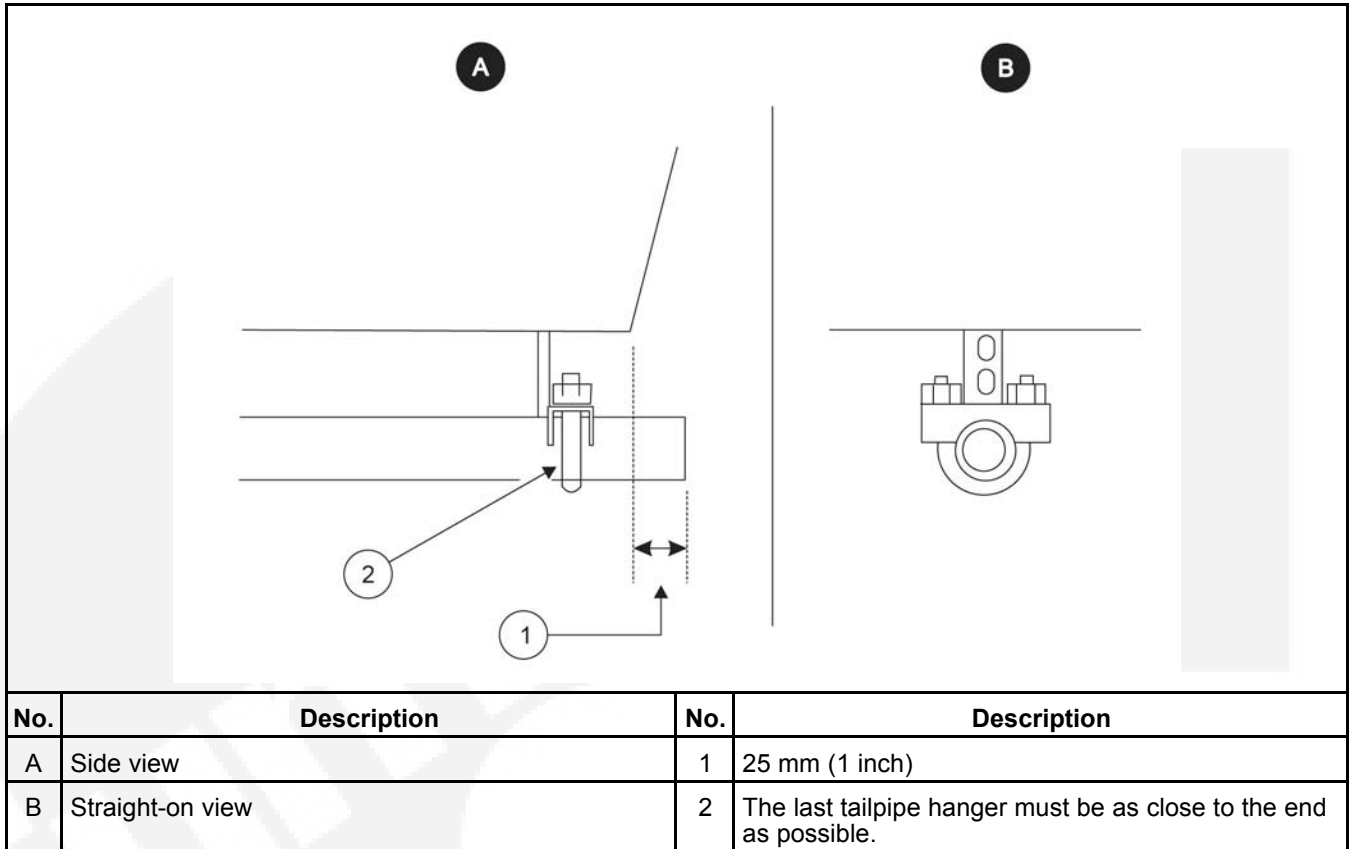

FIGURE 8. TERMINATING THE EXHAUST TAILPIPE

This page is intentionally blank.



5 Fuel Connections

See the Operator Manual for recommended fuels and [Section 2.5 on page 9](#) for fuel consumption.

⚠ CAUTION

Unauthorized modifications or replacement of fuel, exhaust, air intake, or speed control system components that affect engine emissions are prohibited by law in California.

5.1 Gasoline Motorized

The maximum fuel pump lift is 914 mm (36 in).

The generator set and propulsion engine fuel supply and return lines must not be interconnected.

Connections meet the requirements of the following SAE standards, when applicable:

- J1231 (Flared Tube Ends for Hose Connections and Hose Fittings)
- J1508 (Hose Clamp Specifications)
- J2260 (Nonmetallic Fuel System Tubing with One or More Layers)
- J2044 (Quick Connector Specification for Liquid Fuel and Vapor/Emissions Systems)

Terminate the generator set fuel pickup above the vehicle engine pickup in the supply tank to keep the generator set from running the vehicle out of fuel.

Connect 1/4 inch fuel line from the vehicle fuel tank to the generator set.

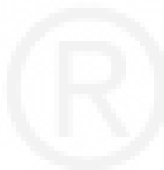

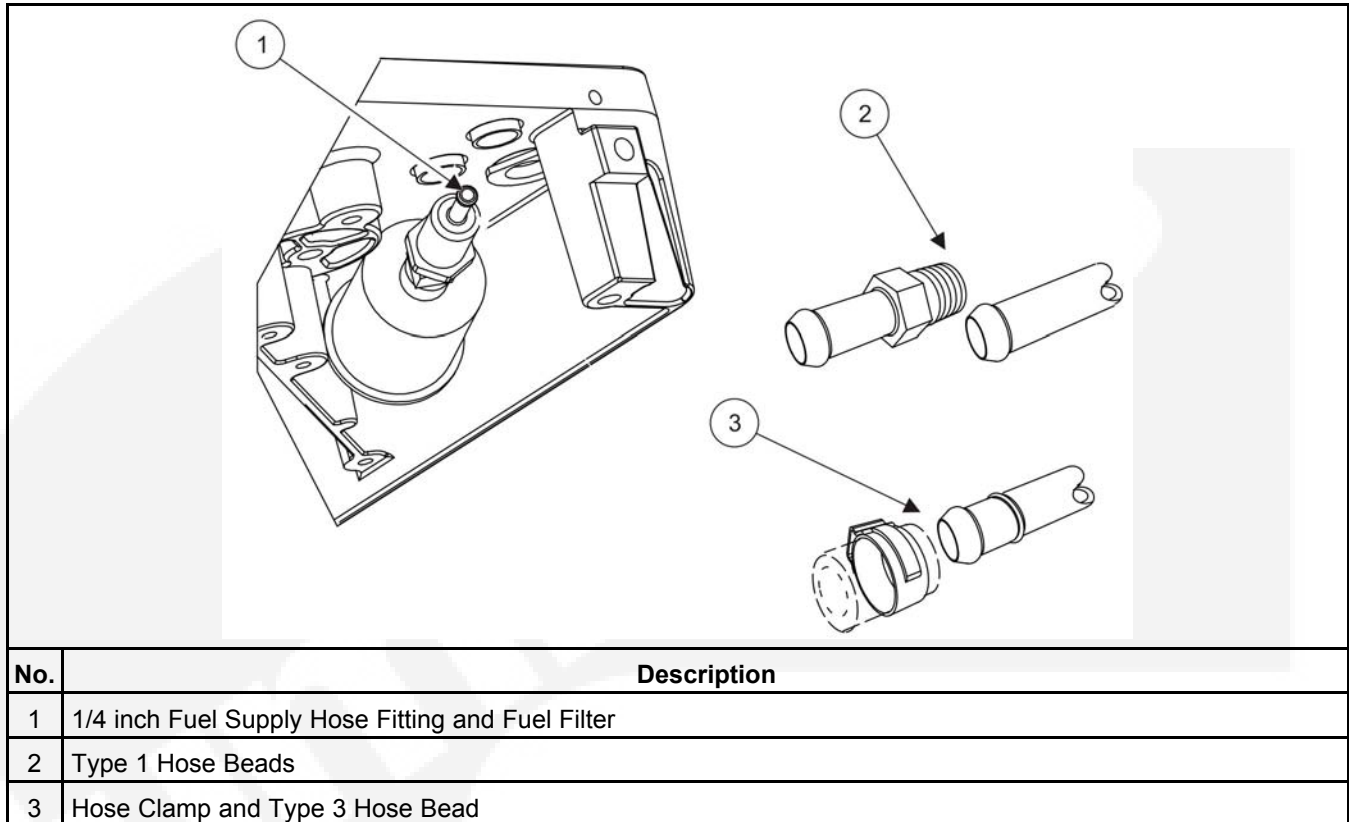

FIGURE 9. GASOLINE MOTORIZED FUEL CONNECTION

5.1.1 Fuel Hoses

The fuel hoses used inside the generator set are low permeation fuel hoses which meet Federal 50 state standards for gasoline evaporative emissions. Low permeation fuel hose is required to meet the requirements for gasoline generator sets sold in or used for commerce in all 50 states. The following hose materials are acceptable:

- Avon Automotive "Greenbar" (EO# G-05-018) SAE J30R7
- Avon Automotive "Greenbar 1200" (EO# C-U-05-009) SAE J30R12
- Gates 4219D (EO# C-U-06-002) SAE J30R9
- Gates Barricade (EO# Q-09-019)
- Kubota (EO# C-U-05-003) SAE J30R7
- Mark IV Automotive "Gen2" (EO# C-U-05-002) SAE J30R7
- Mark IV Automotive "Fluoroperm" (EO# C-U-07-017) SAE J30R9
- Mark IV Automotive "Dayperm" (EO# C-U-06-030) SAE J30R7
- Mark IV Automotive "Dayperm" (EO# G-05-016)
- Mold-Ex Division of SETi, Inc. "SETiFLEX II" (EO# G-05-17A) SAE J30R7
- Parker Hannifin Corp "Super Flex FL-7 series 389XX" (EO# Q-08-013)
- Veyance Technologies Inc. "Goodyear Flexshield" (EO# Q-09-022)

⚠ CAUTION

Lubricants used when connecting fuel hoses can leave residues that can clog fuel jets. Only use soap-free lubricants such as WD40 which runs through with the fuel without leaving residues that can clog fuel jets.

5.1.2 Fuel Lines

Tubing:

- Use 1/4 inch I.D. (± 0.003 inch) welded and drawn Type 304L stainless or AISI 1008-1010 low carbon steel tubing of 0.028 inch minimum wall thickness.
- Tubing must meet requirements for 150 psi operating pressure (Ref. ASTM A 539-99) and have corrosion resistance equal to or better than hot-dipped zinc galvanized.

Hose Beads:

- Use suitable tooling to form tubing ends into SAE J1231 Type 1 or Type 3 double-flare hose beads.
- Recommended for all tubing and fittings.

Flexible Hose: Use 1/4 inch I.D. fuel hose that meets applicable standards for evaporative emissions.

5.1.3 Routing Fuel Lines

⚠ WARNING

Electric arcs can ignite gasoline leading to severe personal injury or death. Do not run wiring and fuel lines together.

1. Route the fuel line along bulkheads and frame members such that it is protected. The entire length of the fuel line must be visible for inspection and accessible for replacement.

It is preferred that fuel line routing be parallel to the motorized chassis fuel line.

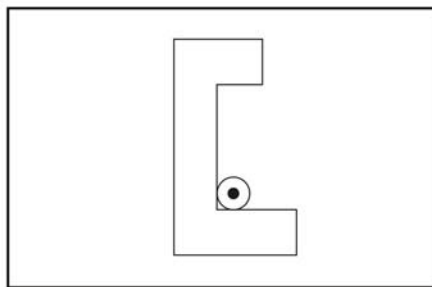

FIGURE 10. FUEL LINE PREFERRED ROUTING

NOTICE

The fuel line should be at or above the top of the fuel tank to reduce siphoning if a line breaks or a hose comes off.

2. Support and protect fuel lines to restrain movement and prevent chaffing or contact with sharp edges, electrical wiring, and hot exhaust parts.

5.2 Gasoline Nonmotorized (Evap)

Evaporative generator sets are used in trailers, fifth wheel trailers, and other non-motorized vehicles where on-board gasoline fuel storage is self-contained in the trailer equipment.

Completing the installation of the generator set fuel evaporative system provides compliance with the California code of regulations for small off-road equipment effective January 1, 2008 and Federal Small SI regulation effective January 1, 2011.

- It is the responsibility of the towable equipment manufacturer OEM to complete the installation of the evaporative fuel system exactly as specified in the CARB EO & EPA certification for the Cummins Onan product being installed. Any deviation from the installation specifications causes forfeiture of the emissions certification on the fuel system and transfers engine evaporative emission certification responsibility to the trailer equipment manufacturer/OEM per CFR 40 Part 1060.
- If purchasing a complete or partial fuel system kit or components from a third party fuel system manufacturer, the requirements of the Installation Manual shall be met and the system must be verified by the OEM and fuel system supplier as meeting these requirements before completing the installation.
- Any construction deviations from these assembly requirements would invalidate the evaporative certification per CFR 40 Part 1060 & Article 1, Chapter 9, Division 3 Title 13 sections 2400 through 2773 and the towable equipment OEM would then be responsible for recertification of the fuel system with California Air Resources Board and US EPA.

Any questions regarding the installation or evaporative emission certification should be directed to Cummins Power Generation for clarification.

Third party companies provide the fuel tank, carbon canister, and all related components with Executive Order (EO) certificates. These products are allowed and the OEM is responsible to meet third party EO requirements.

- The maximum fuel pump lift is 914 mm (36 in).
- The generator set and propulsion engine fuel supply and return lines must not be interconnected.
- Connections meet the requirements of the following SAE standards, when applicable:
 - J1231 (Frosted Tube Ends for Hose Connections and Hose Fittings)
 - J1508 (Hose Clamp Specifications)
 - J2260 (Nonmetallic Fuel System Tubing with One or More Layers)
 - J2044 (Quick Connector Specification for Liquid Fuel and Vapor/Emissions Systems)
 - J2599 (Fuel Filler Pipe Assembly Design Practice to Meet Low Evaporative Emission Requirements)
- Terminate the generator set fuel pickup above the vehicle engine pickup in the supply tank to keep the generator set from running the vehicle out of fuel.
- Connect 1/4 inch fuel line from the vehicle fuel tank to the generator set.

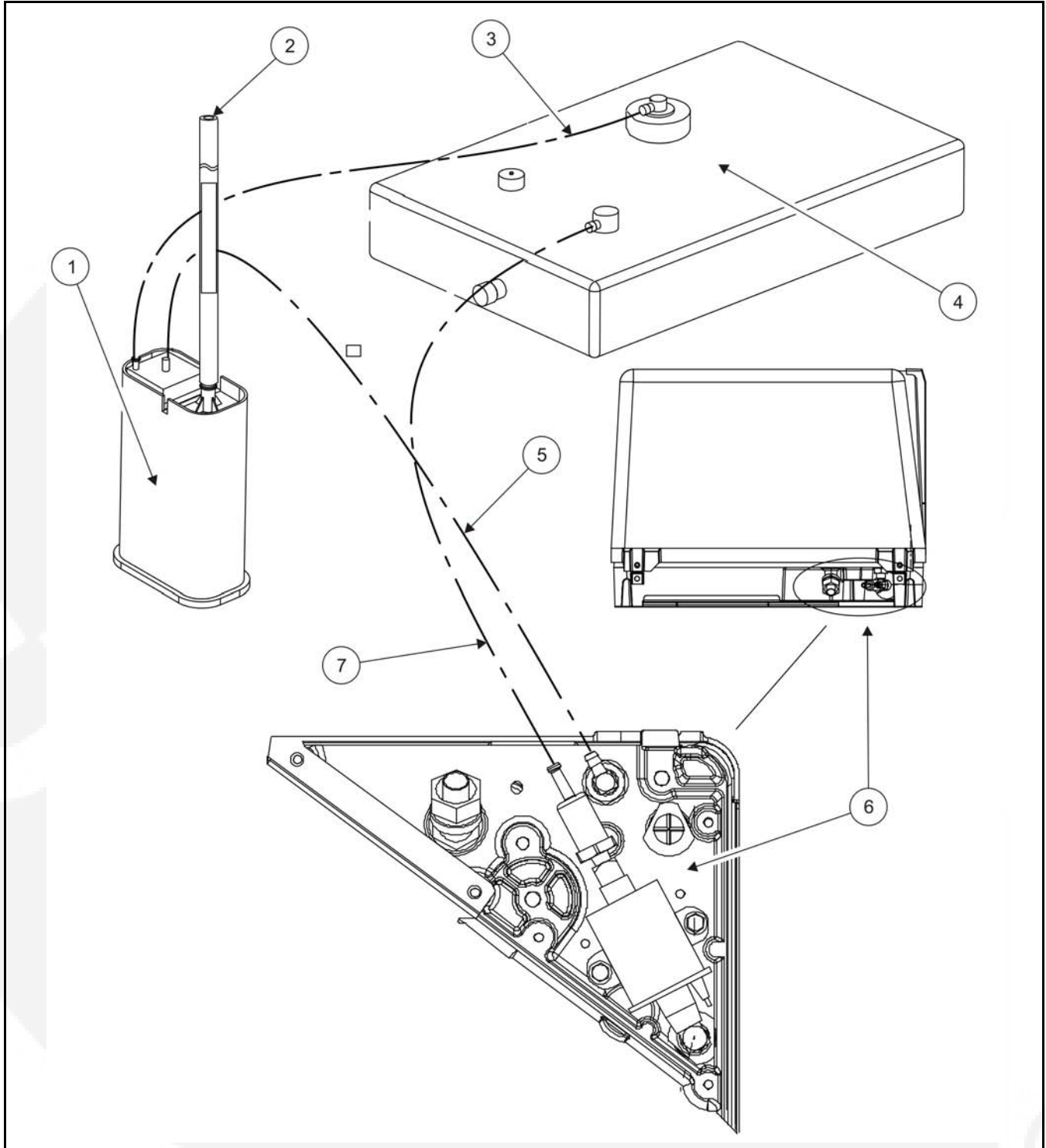

No.	Description	No.	Description
1	Carbon Canister	5	5/16 in Purge Hose (vapor)
2	5/8 in Vent Hose to clean outside air space or PN 0148-1343 Vent Filter	6	Generator Set
3	5/16 in Purge Hose (vapor)	7	1/4 in Fuel Line (liquid)

4	Fuel Tank		
---	-----------	--	--

FIGURE 11. GASOLINE NONMOTORIZED (EVAP) CONNECTIONS

5.2.1 Fuel Hoses

The fuel hoses used inside the generator set are low permeation fuel hoses which meet Federal 50 state standards for gasoline evaporative emissions.

The vapor and liquid hoses connecting the fuel tank to the generator set, the fuel tank to the carbon canister, and the carbon canister to the generator set must also be low permeation fuel hoses. Low permeation fuel hose is required to meet the requirements for gasoline generator sets sold in or used for commerce in all 50 states. The following hose materials are acceptable:

- Avon Automotive "Greenbar" (EO# G-05-018) SAE J30R7
- Avon Automotive "Greenbar 1200" (EO# C-U-05-009) SAE J30R12
- Gates 4219D (EO# C-U-06-002) SAE J30R9
- Gates Barricade (EO# Q-09-019)
- Kubota (EO# C-U-05-003) SAE J30R7
- Mark IV Automotive "Gen2" (EO# C-U-05-002) SAE J30R7
- Mark IV Automotive "Fluoroperm" (EO# C-U-07-017) SAE J30R9
- Mark IV Automotive "Dayperm" (EO# C-U-06-030) SAE J30R7
- Mark IV Automotive "Dayperm" (EO# G-05-016)
- Mold-Ex Division of SETi, Inc. "SETiFLEX II" (EO# G-05-17A) SAE J30R7
- Parker Hannifin Corp "Super Flex FL-7 series 389XX" (EO# Q-08-013)
- Veyance Technologies Inc. "Goodyear Flexshield" (EO# Q-09-022)

⚠ CAUTION

Lubricants used when connecting fuel hoses can leave residues that can clog fuel jets. Only use soap-free lubricants such as WD40 which runs through with the fuel without leaving residues that can clog fuel jets.

5.2.2 Fuel Lines

Tubing:

- Use 5/16 inch O.D. (± 0.003 inch) welded and drawn Type 304L stainless or AISI 1008-1010 low carbon steel tubing of 0.028 inch minimum wall thickness.
- Tubing must meet requirements for 150 psi operating pressure (Ref. ASTM A 539-99) and have corrosion resistance equal to or better than hot-dipped zinc galvanized.

Hose Beads:

- Use suitable tooling to form tubing ends into SAE J1231 Type 1 or Type 3 double-flare hose beads.
- Required for all tubing and fittings.

⚠ CAUTION

When connecting fuel hoses, only use soap-free lubricants such as WD-40, which runs through fuel without leaving residues that can clog fuel jets.

Flexible Hose: Use 5/16 inch I.D. fuel hose that meets SAE J30R9 standards for working pressure and applicable standards for evaporative emissions.

Hose Clamps: Use stainless steel ear clamps.

NOTICE

Onan part number 0503-1951-11 and Oetiker part number 16700011, or equivalent worm screw type clamps are no longer allowed.

5.2.3 Routing Fuel Lines

⚠ WARNING

Electric arcs can ignite gasoline leading to severe personal injury or death. Do not run wiring and fuel lines together.

1. Route the fuel lines side-by-side along bulkheads and frame members such that they are protected. The entire length of the fuel lines must be visible for inspection and accessible for replacement.

NOTICE

The fuel lines should be at or above the top of the fuel tank to reduce siphoning if a line breaks or a hose comes off.

2. Support and protect fuel lines to restrain movement and prevent chaffing or contact with sharp edges, electrical wiring, and hot exhaust parts.

5.2.4 Vapor and Fuel Return Line Requirements

Evaporative (EVAP) requires an additional fuel vapor line from the carbon canister to the generator set.

5.2.5 Fuel Tank

For compliance with evaporative emissions regulations, the fuel tank must:

1. Be metal.
2. Have a 13 to 35 gallon capacity.
3. Have a permanently tethered cap.
4. Have cap that provides a vapor seal and that audibly signals that the vapor seal has been established (click or snap).
5. Have a roll-over vent valve with connection for 5/16 inch I.D. hose. The hose connects to the carbon canister.

6. Have a fill-neck and an anti-spit-back valve if it is a non top-fill tank.
7. Be constructed to meet the requirements of Section 393.67 (joints, fittings and threads) of the Federal Motor Carrier Safety Administration Regulations.

5.2.6 Carbon Canister

Gasoline vapors in the fuel tank accumulate in the carbon canister when the generator set is not running. Vapors are drawn into the engine combustion chamber and burned while the generator set is operating.

Use a Delphi carbon canister shown below. No other carbon canisters are acceptable.

Part Number	Description	Onan Part Number
17208238	3.1 liter, 196 g working capacity	0159-1755
17208262	3.3 liter, 233.8 g working capacity	0159-1754

Mount the canister in one of three orientations shown in the figure below in accordance with its instructions.

NOTICE

Use 5/16 inch hose for vapor lines. Use an SAE J2044 quick connect fuel fitting on the canister hose barb or use a soap-free lubricant such as WD40 to slip the hoses on the canister hose barbs. Secure the hoses with Oetiker® ear-type clamps or equivalent.

Connect the 5/16 inch hose barb (identified by the fuel pump icon) to the hose from the fuel tank and the adjacent 3/8 inch hose barb to the hose from the generator set.

⚠ WARNING

Do not vent the canister (5/8 inch line) into the vehicle or other confined space where the vapors could accumulate to a flammable level.

⚠ CAUTION

Blockage of the canister vent or vent hose could lead to collapse of system components due to vacuum.

To prevent dirt from entering the canister vent when it is mounted in a "dirty" location, connect the 5/8 inch hose barb to a hose terminated outside the living space of the vehicle at a location that is not exposed to road splash or dust. Alternatively, secure Onan Part Number 0148-1343 vent filter to the hose barb.

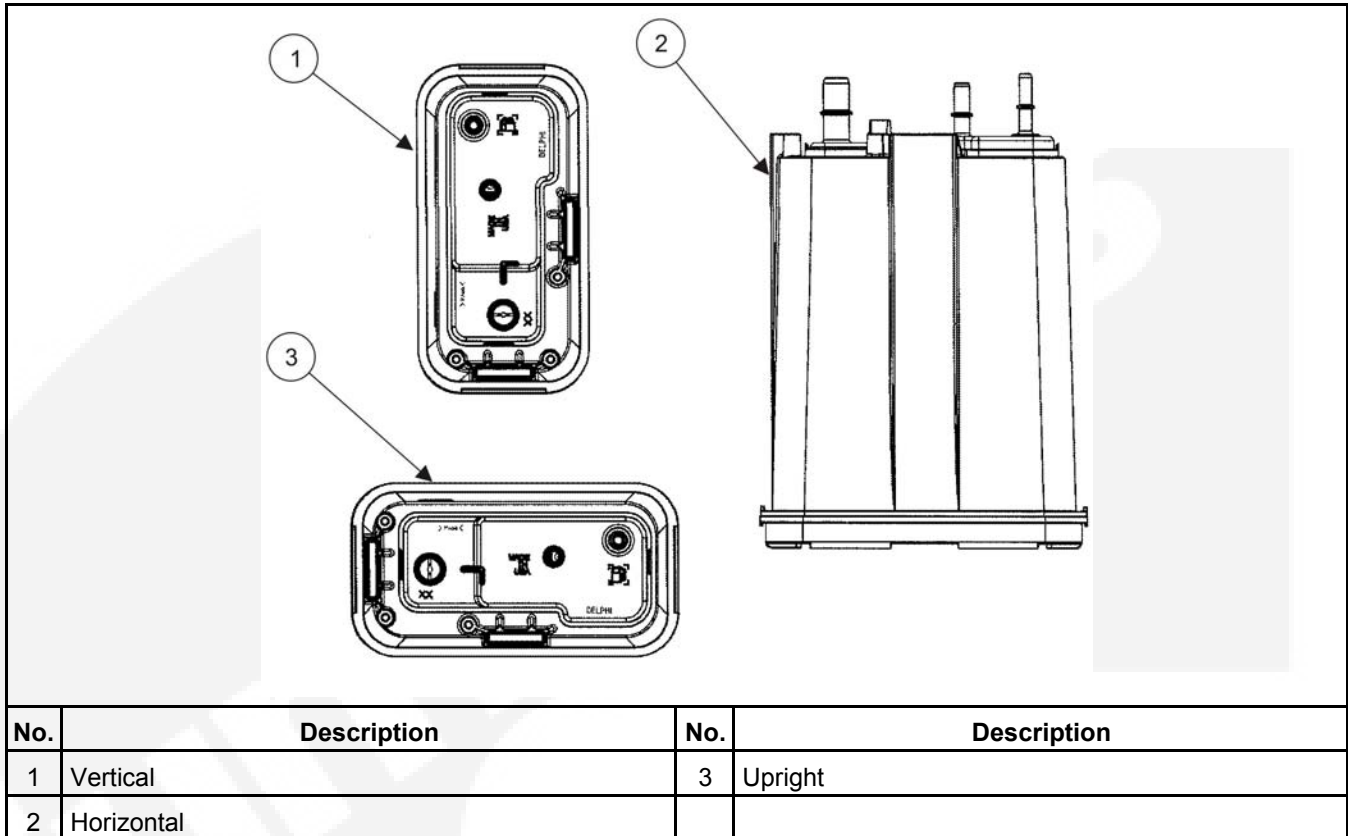

FIGURE 12. ACCEPTABLE CANISTER MOUNTING ORIENTATIONS

5.2.7 Generator Set

1. Connect the 5/16 inch generator set hose barb to the vapor purge hose from the carbon canister.
2. Connect the 1/4 inch hose barb to the fuel supply hose from the fuel tank.

5.3 Gasoline (EFI)

⚠ WARNING

The installer is responsible for meeting all CARB and EPA evaporative emissions requirements that may be applicable for the fuel system. Beginning January 1, 2011 all 50 states require evaporative regulation compliance.

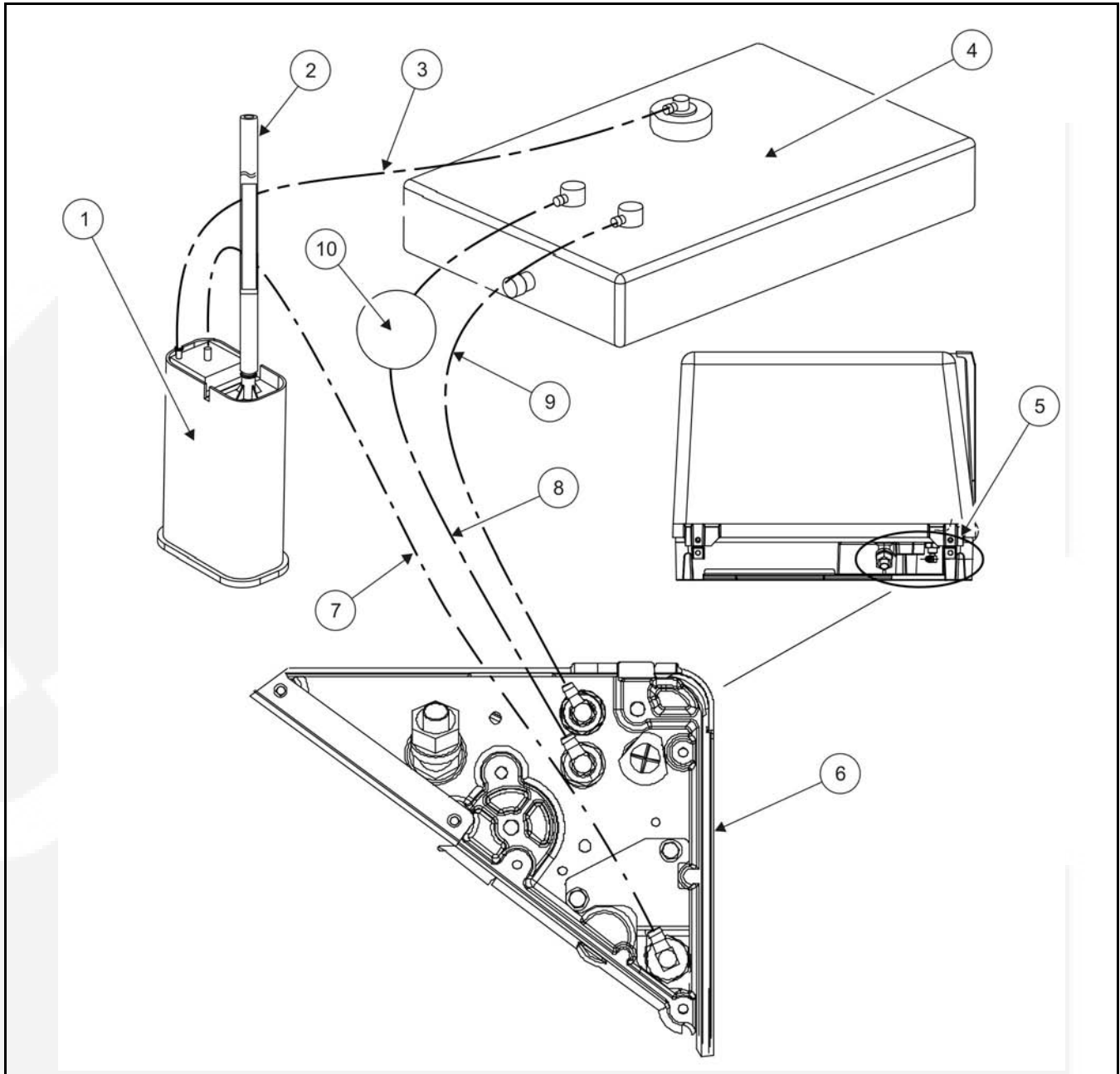

No.	Description	No.	Description
1	Carbon Canister	6	Generator Set (Bottom View)
2	5/8 in Vent Hose to clean outside air space or PN 0148-1343 Vent Filter	7	1/4 in Fuel Line (liquid)
3	5/16 in Purge Hose (vapor)	8	5/16 in Fuel Line from Pump (liquid)
4	Fuel Tank	9	1/4 in Fuel Return Line (liquid)
5	Generator Set (End View)	10	EFI Pump

FIGURE 13. GASOLINE (EFI) CONNECTIONS

5.3.1 Fuel Hoses

The fuel hoses used inside the generator set are low permeation fuel hoses which meet Federal 50 state standards for gasoline evaporative emissions.

The vapor and liquid hoses connecting the fuel tank to the generator set, the fuel tank to the carbon canister, and the carbon canister to the generator set must also be low permeation fuel hoses. Low permeation fuel hose is required to meet the requirements for gasoline generator sets sold in or used for commerce in all 50 states. The following hose materials are acceptable:

- Avon Automotive "Greenbar" (EO# G-05-018) SAE J30R7
- Avon Automotive "Greenbar 1200" (EO# C-U-05-009) SAE J30R12
- Gates 4219D (EO# C-U-06-002) SAE J30R9
- Gates Barricade (EO# Q-09-019)
- Kubota (EO# C-U-05-003) SAE J30R7
- Mark IV Automotive "Gen2" (EO# C-U-05-002) SAE J30R7
- Mark IV Automotive "Fluorperm" (EO# C-U-07-017) SAE J30R9
- Mark IV Automotive Dayperm" (EO# C-U-06-030) SAE J30R7
- Mark IV Automotive "Dayperm" (EO# G-05-016)
- Mold-Ex Division of SETi, Inc. "SETIFLEX II" (EO# G-05-17A) SAE J30R7
- Parker Hannifin Corp "Super Flex FL-7 series 389XX" (EO# Q-08-013)
- Veyance Technologies Inc. "Goodyear Flexshield" (EO# Q-09-022)

⚠ CAUTION

Lubricants used when connecting fuel hoses can leave residues that can clog fuel jets. Only use soap-free lubricants such as WD40 which runs through with the fuel without leaving residues that can clog fuel jets.

5.3.2 Fuel Lines

Tubing:

- Use 5/16 inch O.D. (± 0.003 inch) welded and drawn Type 304L stainless or AISI 1008-1010 low carbon steel tubing of 0.028 inch minimum wall thickness.
- Tubing must meet requirements for 150 psi operating pressure (Ref. ASTM A 539-99) and have corrosion resistance equal to or better than hot-dipped zinc galvanized.

Hose Beads:

- Use suitable tooling to form tubing ends into SAE J1231 Type 1 or Type 3 double-flare hose beads.
- Required for all tubing and fittings.

⚠ CAUTION

When connecting fuel hoses, only use soap-free lubricants such as WD-40, which runs through fuel without leaving residues that can clog fuel jets.

Flexible Hose: Use 5/16 inch I.D. fuel hose that meets SAE J30R9 standards for working pressure and applicable standards for evaporative emissions.

Hose Clamps: Use stainless steel ear clamps.

NOTICE

Onan part number 0503-1951-11 and Oetiker part number 16700011, or equivalent worm screw type clamps are no longer allowed.

5.3.3 Routing Fuel Lines

⚠ WARNING

Electric arcs can ignite gasoline leading to severe personal injury or death. Do not run wiring and fuel lines together.

1. Route the supply and return lines side-by-side along bulkheads and frame members such that they are protected. The entire length of the fuel lines must be visible for inspection and accessible for replacement.

NOTICE

The fuel lines should be at or above the top of the fuel tank to reduce siphoning if a line breaks or a hose comes off.

2. Support fuel lines to restrain movement and prevent chaffing or contact with sharp edges, electrical wiring, and hot exhaust parts.

5.3.4 Vapor and Fuel Return Line Requirements

Electronic fuel injected (EFI) generator sets require a vapor line from the carbon canister to the generator set and a return fuel line from the generator set to the fuel tank.

5.3.5 Fuel Tank

NOTICE

Do not change or remove the fuel fill tube, fill limiter vent, vapor canister, vapor lines, filler cap, or any other part of the fuel system without the express approval of the vehicle chassis manufacturer. Modification must conform with application sections of the Code of Federal Regulations, Titles 40 and 49, and other standards.

Onan requires a separate fuel pickup tube or a separate fuel tank for the generator set. The generator set must never be connected to the fuel supply line of the vehicle engine—either to a high-pressure system (pump in tank) that can overpressureize the generator set fuel system, or a vacuum system (pump in engine) that can cause the generator set to starve for fuel. Some vehicle chassis manufacturers allow connections to the fuel return line on high pressure fuel systems. Contact the vehicle chassis manufacturer for approval.

⚠ WARNING

Excessive fuel pressure can flood the generator set causing a fire. Generator set fuel supply line pressure must not exceed 1-1/2 psi under any condition.

Fuel line pressure at the point where the generator set is connected must not exceed 1-1/2 psi under any condition.

The EFI fuel pump can pump fuel significantly better than it can draw fuel out of the main tank. For this reason, locate the high pressure EFI pump as close to the tank pickup as possible.

Terminate the generator set fuel pickup above the vehicle engine pickup in the supply tank to keep the generator set from running the vehicle out of fuel.

5.3.6 Carbon Canister

Gasoline vapors in the fuel tank accumulate in the carbon canister when the generator set is not running. Vapors are drawn into the engine combustion chamber and burned while the generator set is operating.

Use a Delphi carbon canister shown below. No other carbon canisters are acceptable.

Part Number	Description	Onan Part Number
17208238	3.1 liter, 196 g working capacity	0159-1755
17208262	3.3 liter, 233.8 g working capacity	0159-1754

Mount the canister in one of three orientations shown in the figure below in accordance with its instructions.

NOTICE

Use 5/16 inch hose for vapor lines. Use an SAE J2044 quick connect fuel fitting on the canister hose barb or use a soap-free lubricant such as WD40 to slip the hoses on the canister hose barbs. Secure the hoses with Oeitiker® ear-type clamps or equivalent.

Connect the 5/16 inch hose barb (identified by the fuel pump icon) to the hose from the fuel tank and the adjacent 3/8 inch hose barb to the hose from the generator set.

⚠ WARNING

Do not vent the canister (5/8 inch line) into the vehicle or other confined space where the vapors could accumulate to a flammable level.

⚠ CAUTION

Blockage of the canister vent or vent hose could lead to collapse of system components due to vacuum.

To prevent dirt from entering the canister vent when it is mounted in a “dirty” location, connect the 5/8 inch hose barb to a hose terminated outside the living space of the vehicle at a location that is not exposed to road splash or dust. Alternatively, secure Onan Part Number 0148-1343 vent filter to the hose barb.

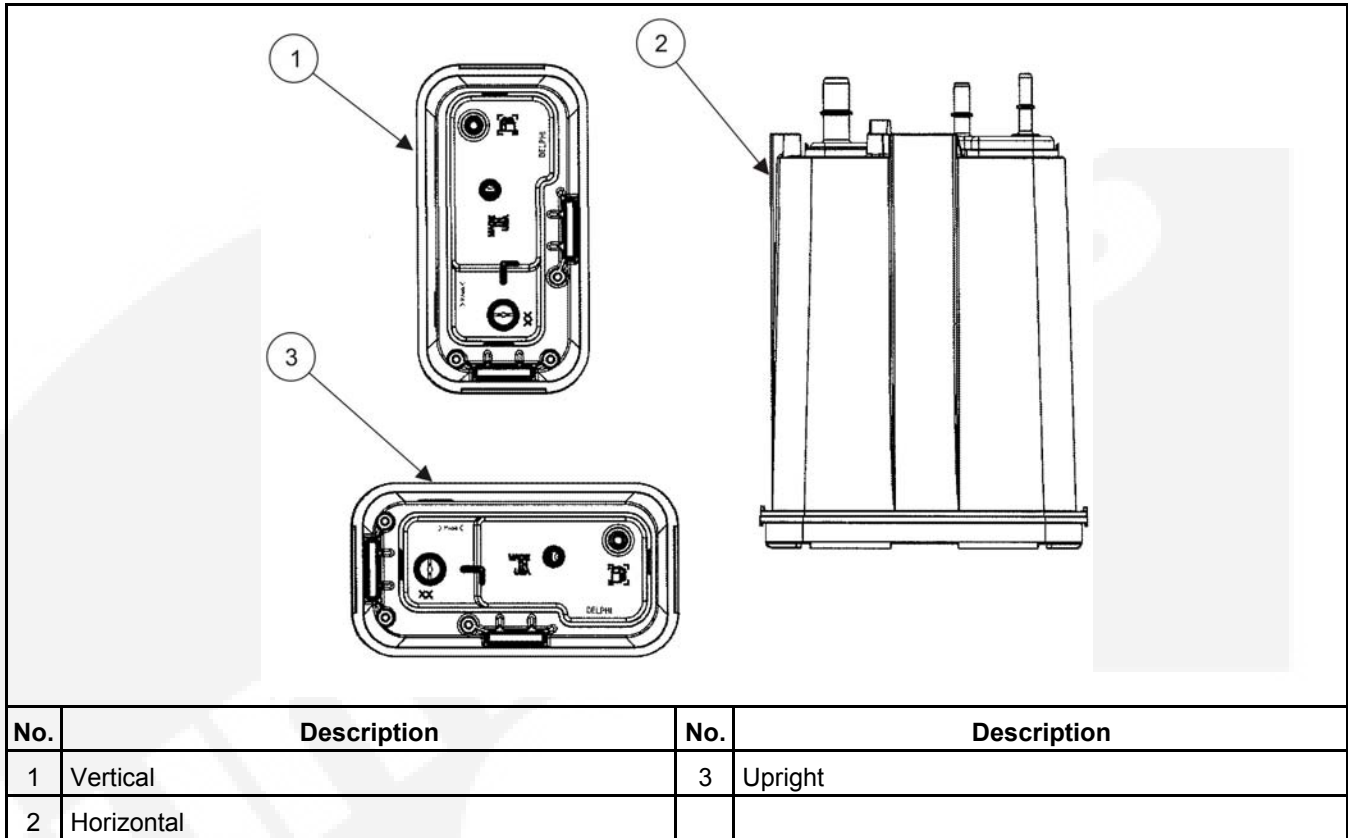

FIGURE 14. ACCEPTABLE CANISTER MOUNTING ORIENTATIONS

5.3.7 Remote Fuel Pump Kit

The fuel injection system is supplied by a remote electric pump. Install the pump kit made for the model of the vehicle in which the generator set is installed.

Follow the installation instructions in the pump kit.

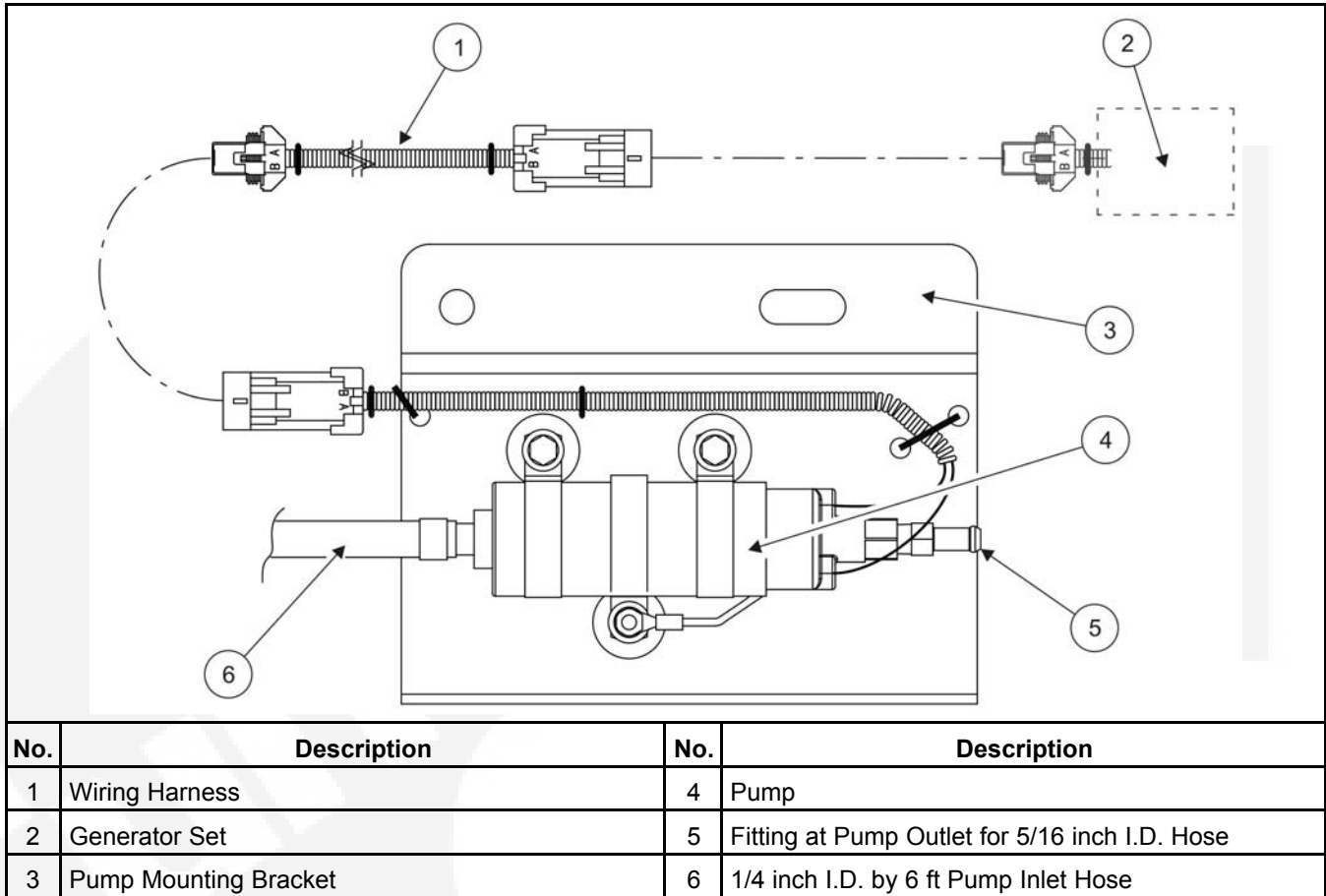

FIGURE 15. FUEL PUMP KIT

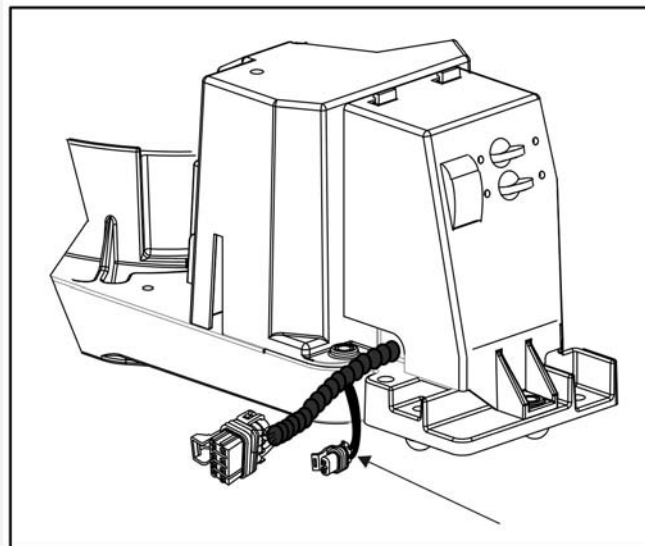

FIGURE 16. REMOTE PUMP WIRING CONNECTOR

5.3.8 Fuel Supply Line Pump to Generator Set

1. Connect the 5/16 inch generator set hose barb to the vapor hose from the carbon canister.

2. Connect the 1/4 inch generator set hose barb to the fuel supply hose from the fuel tank.

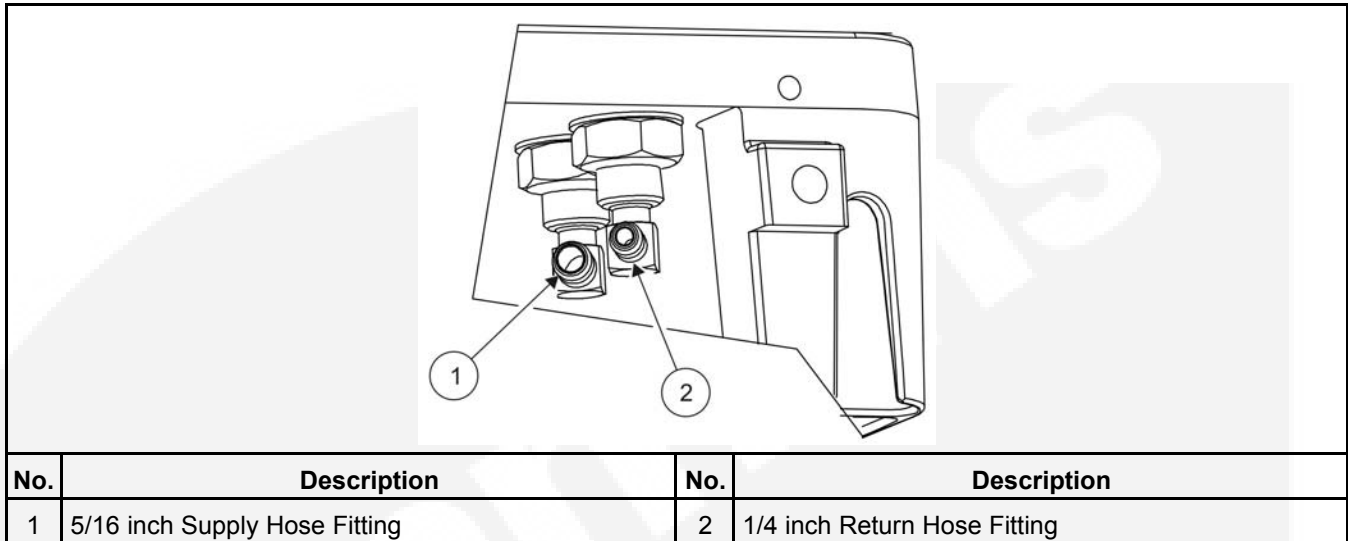

FIGURE 17. FUEL FITTINGS—LEFT END OF BASE

5.3.9 Generator Set

1. Connect the 5/16 inch generator set hose barb farthest from the corner of the base to the vapor purge hose from the carbon canister.
2. Connect the other 5/16 inch hose barb to the fuel supply hose from the fuel pump.
3. Connect the 1/4 inch hose barb to the fuel supply hose.

5.4 LPG

⚠ WARNING

LPG is flammable and explosive and can cause asphyxiation. NFPA 58, Section 1.6 requires all persons handling LPG to be trained in proper handling and operating procedures.

⚠ WARNING

High LPG supply pressure can cause gas leaks which can lead to fire and severe personal injury or death. LPG supply pressure must be adjusted to Specifications by trained and experienced personnel.

⚠ WARNING

Sparks can ignite LPG, leading to severe personal injury or death. Do not run electrical wiring and fuel lines together. Separate them with conduit or tubing if run through the same opening. Do not tie them together.

⚠ WARNING

LPG leaks from the vent hose can lead to explosive accumulations inside the generator set compartment. Route the LPG vent hose so that it vents to the outside or provide required openings.

⚠ WARNING

The flameout of an unvented LPG appliance can lead to explosive accumulations of gas inside the vehicle and the danger of severe personal injury or death. Do not connect the generator set fuel supply line to any vehicle appliance supply line.

⚠ WARNING

Testing for gas leaks with a flame can cause a fire or explosion that could lead to severe personal injury or death. use approved methods only.

NFPA 58, the Standard for the Storage and Handling of Liquefied Petroleum Gases (NFPA 58) should be used as a guide for the installation of the LPG fuel system.

NFPA 1192, the Standard on Recreation Vehicles for Liquefied Petroleum Gases should be used as a guide for the installation of the LPG fuel system in regard to the following sections:

- Propane Container
- Propane Supply Connection/Connector
- Regulated High Pressure Piping
- Propane Systems
- Propane Piping Systems
- Propane Piping Design
- Propane Pipe Sizing

NOTICE

Generator is included in pipe sizing calculations and testing.

- Special Requirement for High Pressure Testing
- Testing Low-Pressure Piping Systems for Propane Leakage After Appliances are Connected

NOTICE

Generator is considered connected as an appliance for testing.

- Testing Regulated High-Pressure Piping System for Gas Leakage

Connect LPG fuel system:

1. Adjust the gas supply pressure (at the gas inlet of the pressure regulator) to at least 229 mm (9 in) Water Column (WC). The pressure must not exceed 330 mm (13 in) WC.
2. Route LPG fuel lines away from electrical wiring and hot engine exhaust components. Fuel lines should be accessible for inspection and replacement, protected from damage, and secured to prevent kinking, contact with sharp edges, and chafing due to vibration.
3. Route the LPG vent hose so that it vents to the outside or provide required openings.
4. For a long fuel line run, use seamless steel tubing with flared ends. Make flexible hose connections at the fuel tank and at the generator set. Use 3/8 inch I.D. fuel line for runs up to 0.9 m (3 ft) and 1/2 inch I.D. up to 4.6 m (15 ft).

Do not connect the generator set fuel supply line to any appliance fuel supply line. The generator set can draw fuel away from other appliances and cause a flame out. To prevent the possibility of flameout, the fuel supply system must be designed to deliver sufficient fuel for normal operation of the generator set and other appliances at the expected temperature conditions. It may be necessary to use a separate fuel tank for the generator set if sufficient fuel cannot be supplied with a single tank system.

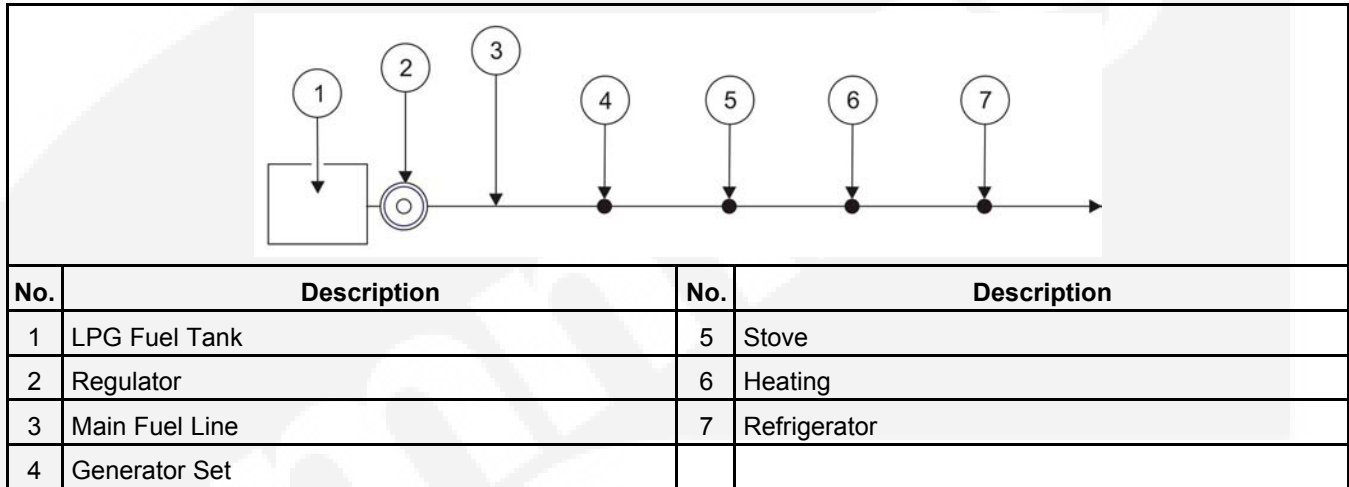

FIGURE 18. LPG FUEL LINE APPLIANCE CONNECTIONS (2.5 THROUGH 5.5 KW LPG SYSTEMS)

LPG systems with 6.5 kW must have dedicated:

- Tank
- Regulator
- Piping/Connections

Upon completion of the installation, fill the LPG tank and test every joint and fitting in the LPG supply system using an approved method, such as soap bubbles.

Because variations in fuel, altitude, and ambient temperature affect performance, it might be necessary to make governor and fuel mixture adjustments once the generator set has been installed. See the Service Manual.

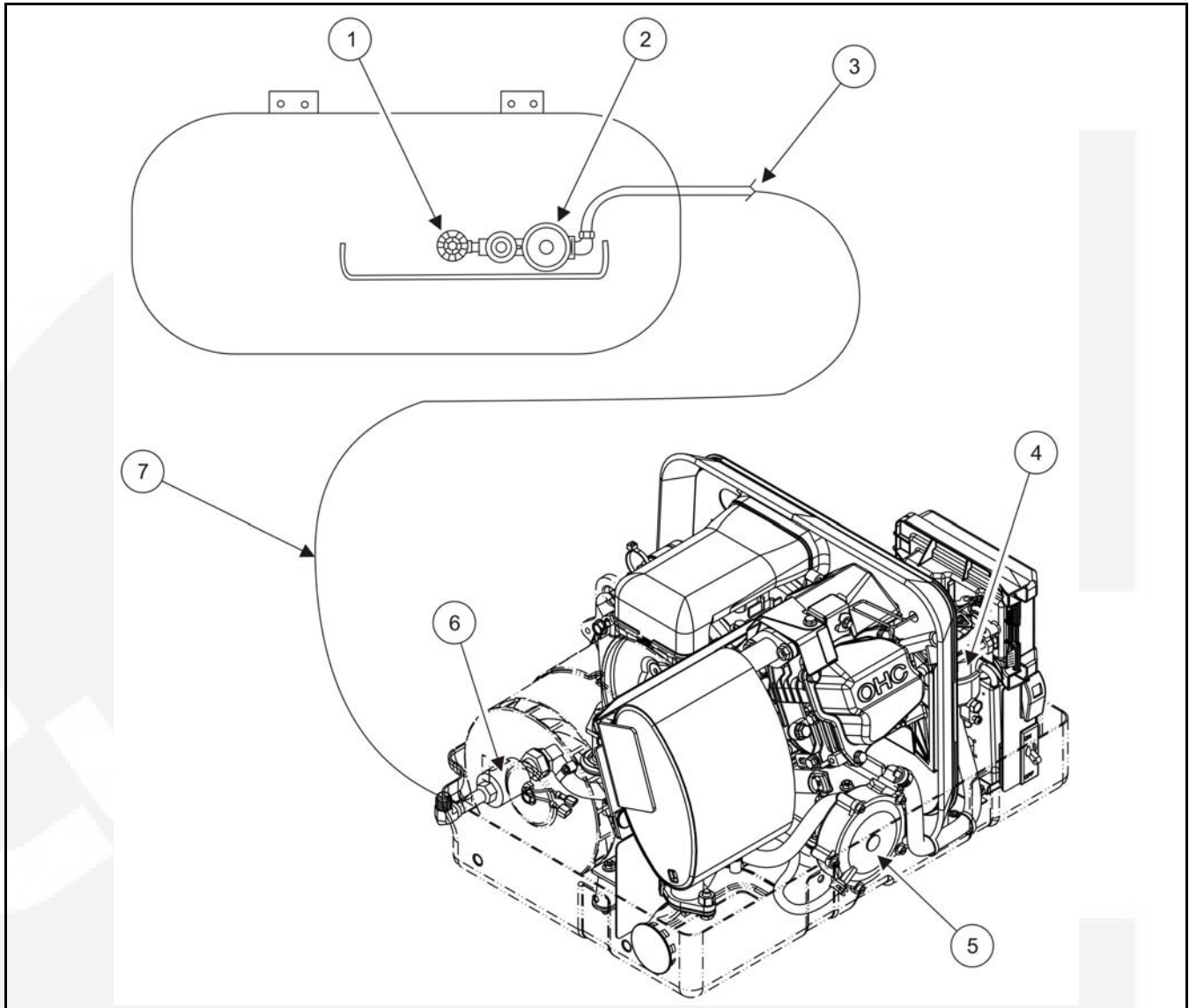

No.	Description	No.	Description
1	Vapor Shutoff Valve	6	Fuel Shutoff Solenoid
2	Two Stage Regulator	7	Fuel Line Size: 3/8 inch I.D. up to 0.9 m (3 ft) or 1/2 inch I.D. up to 4.6 m (15 ft)
3	11 inches W.C. Outlet Pressure	8	LPG Vent Hose (vent outside compartment)
4	LPG Carburetor	9	5/8-18 45° Flare Fitting
5	Demand Regulator		

FIGURE 19. TYPICAL LPG VAPOR WITHDRAWAL FUEL SYSTEM



This page is intentionally blank.



6 Electrical Connections

⚠ WARNING

HAZARDOUS VOLTAGE! Touching uninsulated live parts inside the generator set and connected equipment can result in severe personal injury or death. For your protection, stand on a dry wooden platform or rubber insulating mat, make sure your clothing and shoes are dry, remove jewelry from your hands, and use tools with insulated handles. Secure protective covers when completing installation.

⚠ WARNING

IMPROPER WIRING can cause fire or electric shock resulting in severe personal injury or death.

⚠ WARNING

Accidental starting of the generator set can cause severe personal injury or death. Do not connect the starting battery until instructed in [Chapter 7 on page 53](#).

6.1 AC Power Output Connections

The generator set is equipped with a circuit breaker and 3 m (120 in) long 30-A (10 AWG) leads for AC power output which exit through a rain-tight 1/2 inch trade size conduit connector.

The leads can be terminated at the main AC distribution panel where individual breakers can be provided for vehicle/trailer AC loads.

If longer AC cable is required or code stipulates, a 4 x 4 inch junction box is mounted near the generator set. Use a weather type junction box if it is exposed to the elements. When extending this cable, use the proper size wire for amperage and insulation temperature rated wire (typically 10 AWG) to the main AC distribution panel.

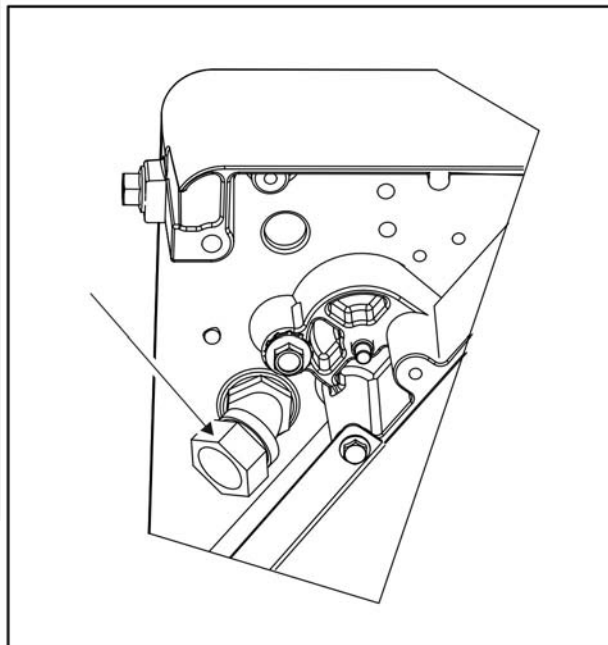

FIGURE 20. AC OUTPUT CONDUIT

6.1.1 Wiring Methods

Follow the National Electrical Code, especially noting the following:

1. Have a qualified electrician supervise and inspect the installation of all AC wiring.
2. Install vibration-proof switches and controls that won't open and close circuits when the vehicle is in motion.
3. Provide ground fault circuit interrupters (GFCIs) for all convenience power receptacles.
4. Route AC wiring, remote control wiring, and fuel lines separately.
5. Seal all conduit openings into the vehicle interior to keep out exhaust gas. Apply silicone rubber or an equivalent type of sealant inside and outside each conduit connector. (Flexible conduit is not vapor tight and will allow exhaust gas to enter along the wires if not sealed.)

⚠ WARNING

Faulty grounding can lead to fire and electrocution, resulting in severe personal injury or death. Grounding must be in accordance with applicable codes.

6. Bond the generator set and all connected AC and DC equipment and controls to a common grounding point in accordance with applicable codes.

6.1.2 Connecting to Shore Power

⚠ WARNING

Interconnecting the generator set and shore power can lead to electrocution of utility line workers, equipment damage, and fire. Use an approved switching device to prevent interconnections.

A vehicle with provisions for connecting to utility power must have an approved device to keep the generator set and utility from being interconnected.

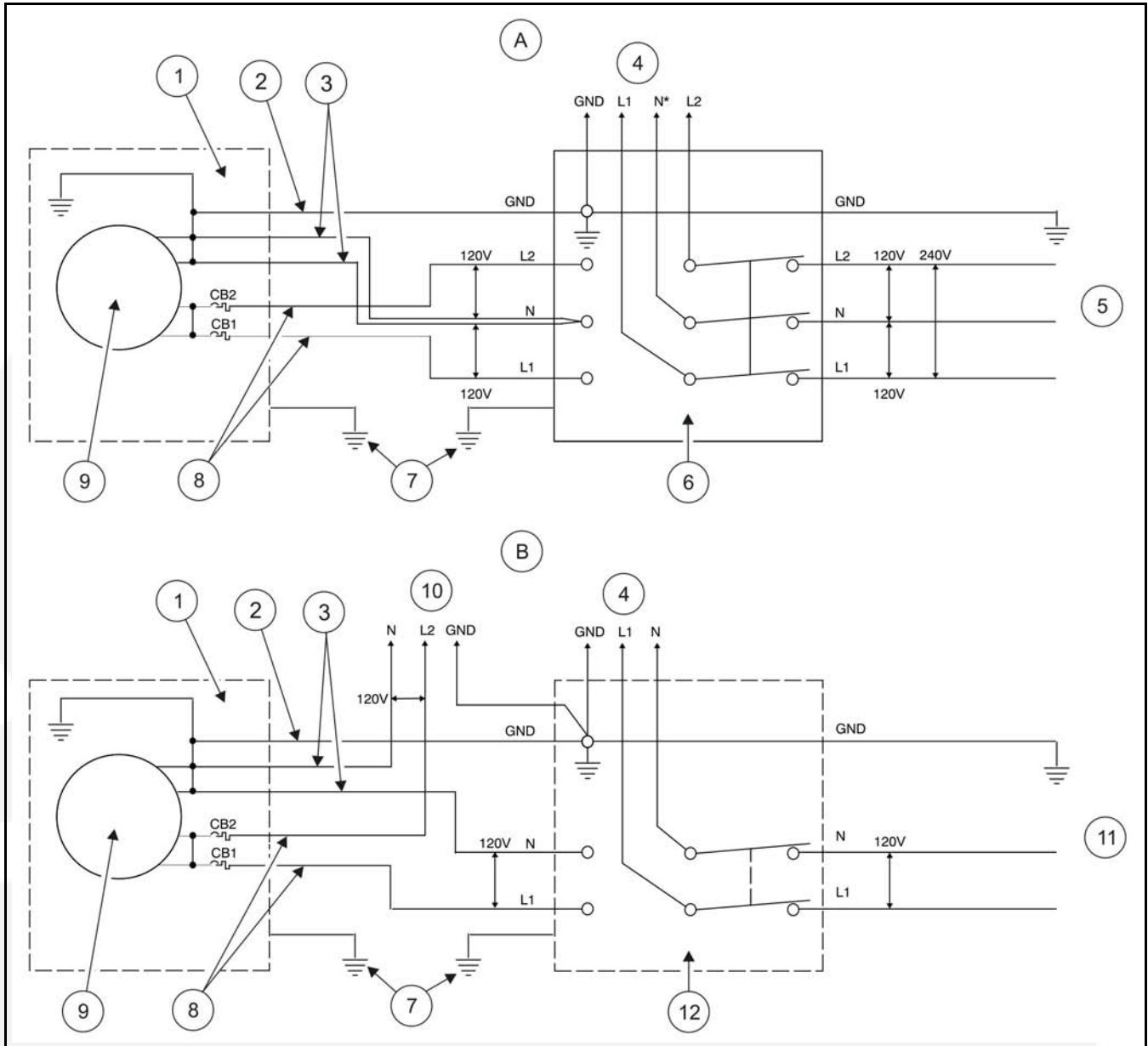

No.	Description	No.	Description
1	Generator Set	7	Chassis Bonds
2	Green	8	Black
3	White	9	Generator
4	To Vehicle AC Distribution Panel	10	To Rear Air Conditioner
5	50 Amp Shore Power	11	30 Amp Shore Power
6	3-Pole Transfer Switch	12	2-Pole Transfer Switch

FIGURE 21. TYPICAL CONNECTIONS WITH TRANSFER SWITCH AND UTILITY

6.2 Remote Control Connections

The generator set has an 8-pin connector for remote control connections. Wiring harnesses in several lengths are available separately for connections between the generator set and remote control panel.

To make connections to a remote control panel:

1. Push the generator set remote control connector through the entrance hole in the side of the generator set housing and snap it together with the remote wiring harness connector male.
2. Refer to the following table to fabricate the remote control panel and/or wiring harness when not using the accessories available from Cummins Onan. Mark the remote control end of each lead to identify the connector pin number at the generator set.

Use insulated 18 AWG copper conductors for distances up to 9 m (30 ft) and heavier gauge conductors for greater distances. Protect the wiring with full-length flexible sheathing.

3. Route control leads separately from AC power leads to reduce the possibility of erratic operation due to false induced signals.
4. Seal the opening where the leads enter the vehicle interior with silicone rubber or equivalent sealant to keep out exhaust gas.

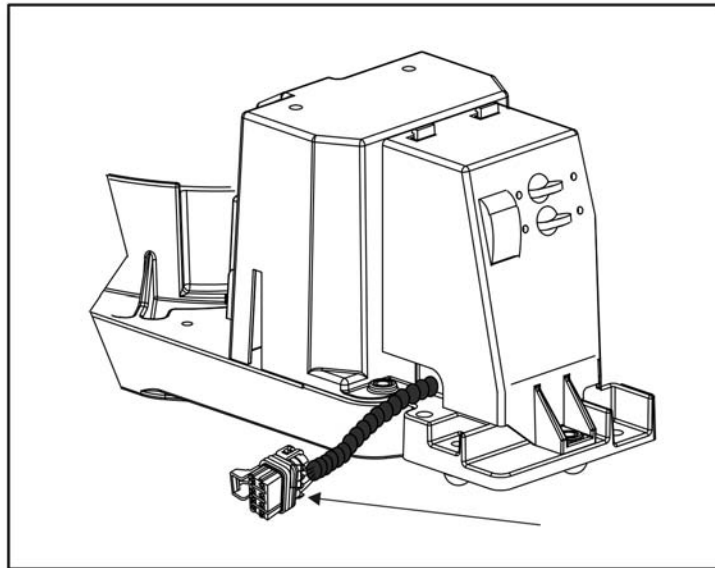

FIGURE 22. REMOTE CONTROL CONNECTOR

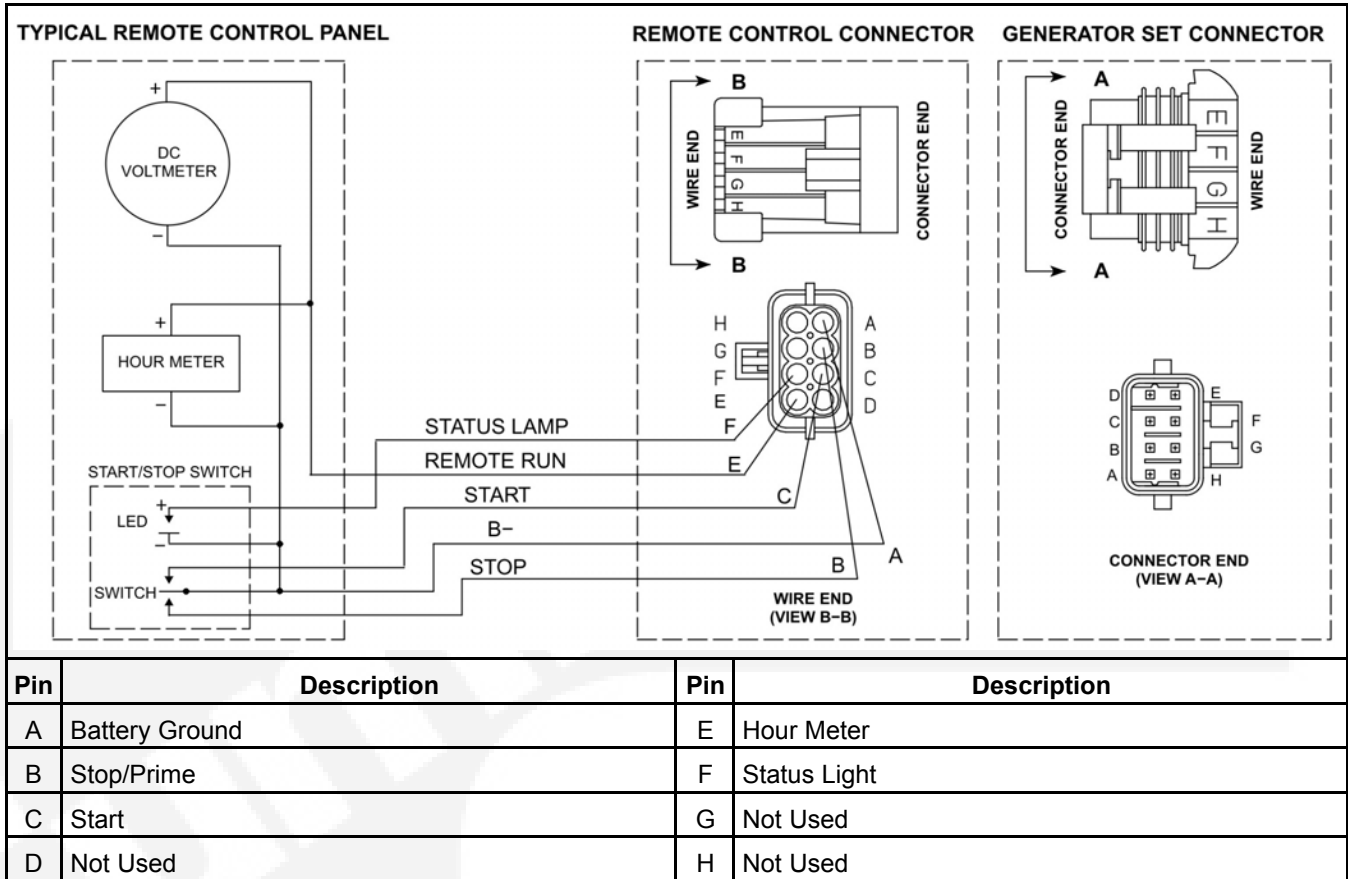

FIGURE 23. REMOTE CONTROL CONNECTOR PLUG AND TYPICAL CONNECTIONS

6.3 Starting Battery Connections

⚠ WARNING

Accidental starting of the generator set can cause severe personal injury or death. Do not connect the starting battery until instructed in [Chapter 7 on page 53](#).

The generator set has a 12 VDC, negative-ground engine control and cranking system. See [Section 2.5 on page 9](#) for the requirements for cranking batteries.

6.3.1 Battery Compartment

⚠ WARNING

Arcing can ignite the explosive hydrogen gas given off by the battery, causing severe personal injury. The battery compartment must be ventilated and must isolate the battery from spark-producing equipment.

Batteries must be mounted in a separate compartment from that of the generator set and away from spark-producing equipment. A compartment must have openings of at least 11 cm² (1.7 in²) at the top and bottom for ventilation of battery gasses. It should be mounted such that spills and leaks will not drip acid on fuel lines, wiring, and other equipment that could be damaged.

- Stand-alone applications will require a starting battery and a battery charger.
- RVs often connect "house" batteries to the generator set. All RVs should be equipped with a battery charger to charge the batteries.

6.3.2 Battery Cable Sizes

TABLE 7. BATTERY CABLE SIZES FOR TEMPERATURES DOWN TO -29 °C (-20 °F)

Total Cable Length ¹	Cable Size
0 to 13.7 m (0 to 45 ft)	2 AWG ²
14 to 18.3 m (46 to 60 ft)	0 AWG
18.6 to 24.4 m (61 to 80 ft)	00 AWG

1. Battery cable lengths are total lengths from battery to the generator back to the battery and when using a total of 1000 CCA (Cold Cranking Amps).
2. A total length of up to 6 m (20 ft) may be used in warmer climates or when battery capacity totals at least 1000 CCA.

6.3.3 Battery Cables

Size battery cables according to the Battery Cable Sizes table. The current path between the generator set and the negative (-) battery terminal must also be able to carry full cranking current without causing excessive voltage drop. It is highly recommended that a full-length cable be used to connect the generator set to the negative (-) battery terminal. Note also that codes may require bonding conductors from the generator set and the battery to the vehicle frame.

If a vehicle frame is used as the path between the negative (-) battery terminal and the generator set, all frame members in the path of battery cranking currents must have substantial crosssections. The electrical resistance of riveted or bolted frame joints must also be carefully considered, especially if the joints will be exposed to corrosive conditions. A cable must be used to connect the frame to the designated negative (-) terminal on the generator set.

NOTICE

The generator set mounting bolts are not considered an adequate means of bonding the generator set to the vehicle frame, either for the purpose of carrying cranking currents or for complying with requirements for generator set/system grounding.

Coat all battery cable connections with a battery terminal oxidation inhibitor.

⚠ WARNING

Routing battery cables with fuel lines can lead to fire and severe personal injury or death. Keep battery cables away from fuel lines.

Route battery cables away from fuel lines and hot engine exhaust components. Battery cables should be accessible for inspection and replacement, protected from damage and secured to prevent chafing due to vibration.

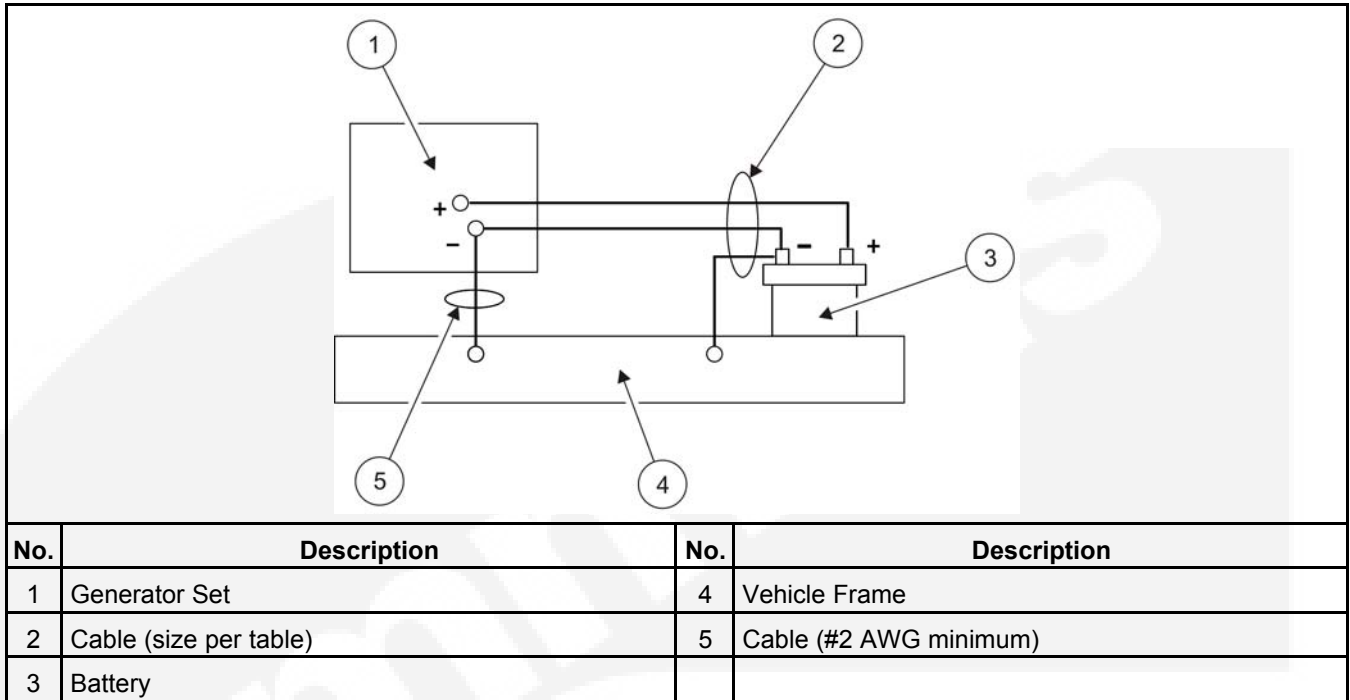

FIGURE 24. FULL-LENGTH CABLE FROM BATTERY NEGATIVE (-) TERMINAL

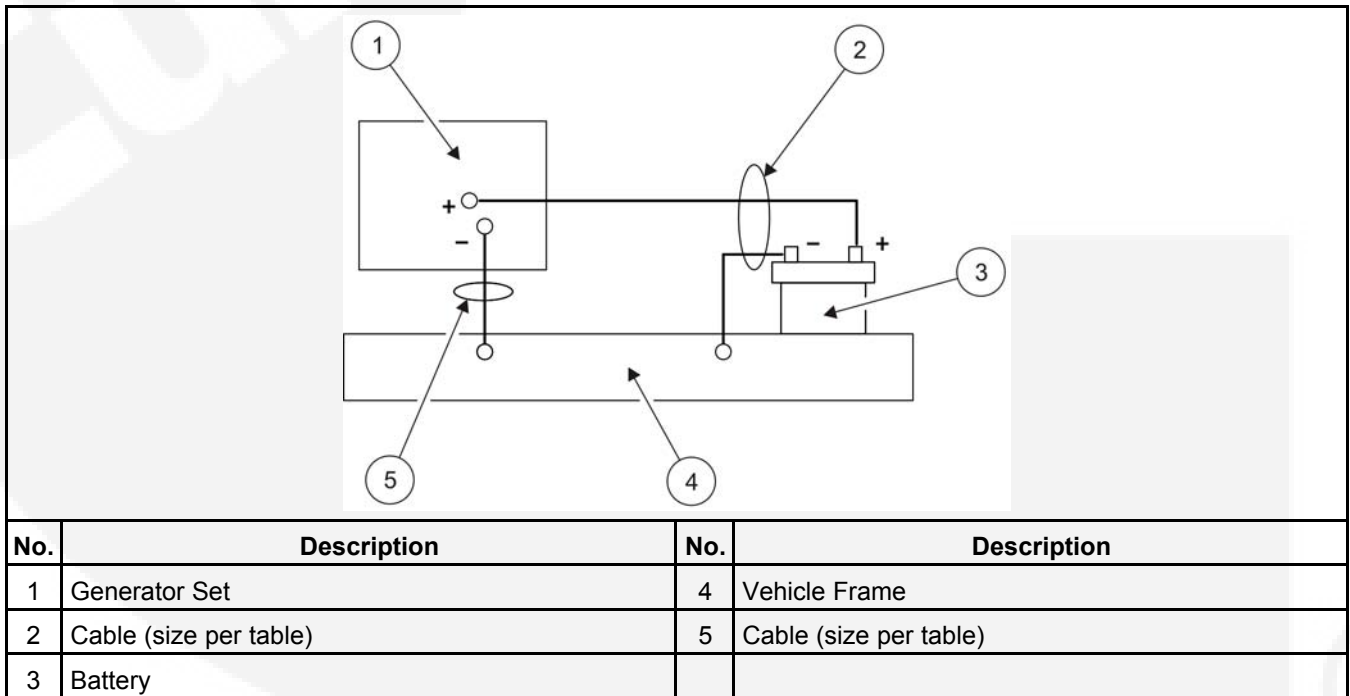

FIGURE 25. VEHICLE FRAME AS PATH FROM BATTERY NEGATIVE (-) TERMINAL

6.3.4 Battery Cable Connections at the Generator Set

Terminate the battery cables with ring terminals sized for 5/16 inch screws and connect them to the generator set. Secure the insulating boot on the positive (+) terminal and tie it to the battery cable with the tie-wrap in the bag with the manuals.

Torque the positive (+) cable terminal to 6 Nm (4.5 ft-lbs).

Torque the negative (-) cable terminal to 11 Nm (8 ft-lbs).

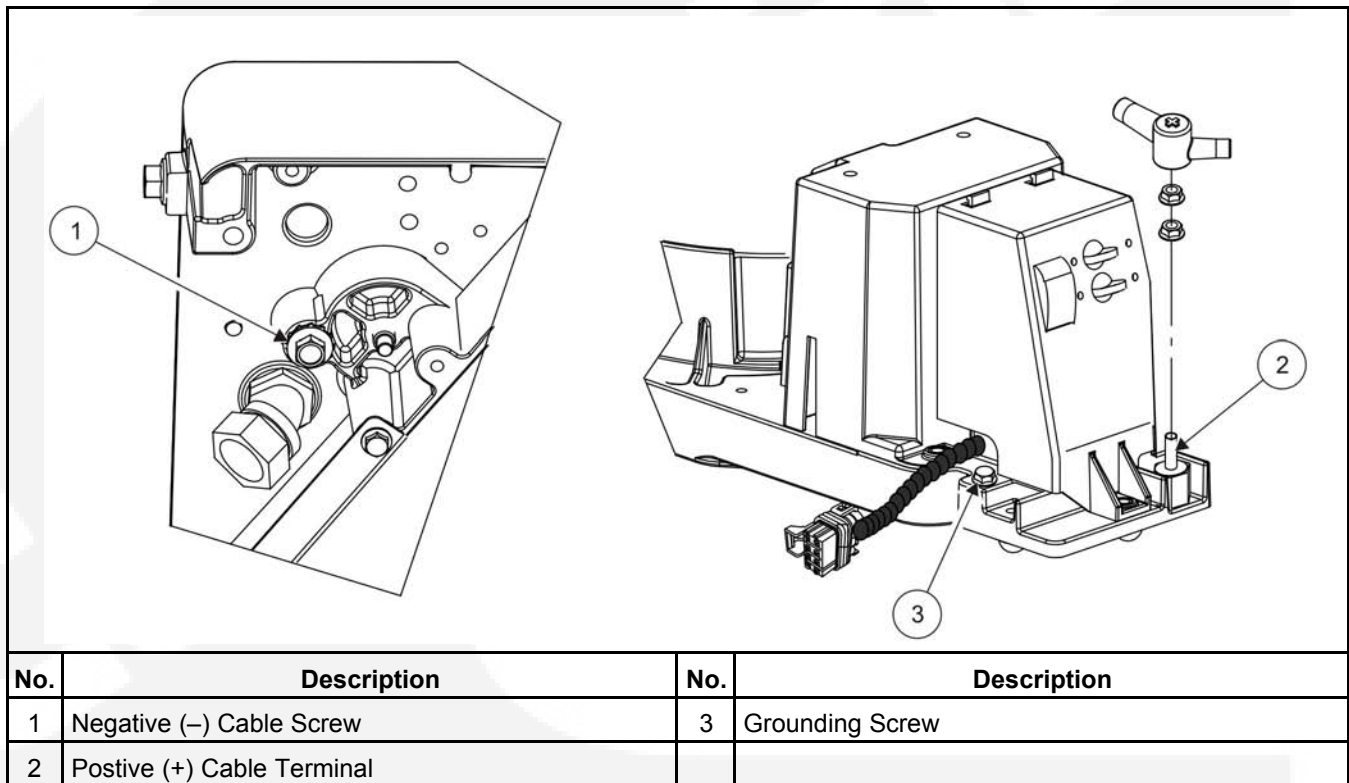

FIGURE 26. BATTERY CABLE CONNECTIONS

6.3.5 Generator Set (Equipment) Grounding Screw

When required, connect the generator set grounding screw to the vehicle frame with a No. 8 AWG or larger stranded cable having a ring terminal sized for a 3/8 inch screw.

Torque the grounding screw to 11 Nm (8 ft-lbs).

7 Installation Review and Startup

7.1 Installation Review

Before starting the generator set, inspect the installation and check (✓) each of the following questions if it can be answered "YES." If an item cannot be checked, provision must be made to satisfy the requirement.

- Is the control panel on the generator set easily accessible for starting and stopping the generator set and resetting the circuit breaker?
- Is there easy access for checking and adding engine oil, replacing the spark plugs, and changing the air filter?
- Is the generator set securely bolted in place?
- Are all specified clearances provided?
- Are the air inlet and outlet openings free of obstructions?
- Is there access for draining engine oil?
- Are all tail pipe connections tight and all hangers and support straps secure?
- Does the tailpipe terminate at least 25 mm (1 in) beyond the perimeter of the vehicle and at least 153 mm (6 in) away from any opening into the vehicle?
- Is the generator set located outside the vehicle interior or separated by approved vapor- and fire-resistive materials?
- Are all openings into the vehicle, such as for AC wiring, sealed to keep out engine exhaust? Are AC conduit connectors sealed inside and outside?
- Have all AC connections been inspected and approved?
- Has a properly sized battery been installed in a ventilated compartment isolated from the generator set?
- Have properly sized battery cables been installed and secured at sufficient intervals to prevent chaffing and contact with sharp edges, fuel lines, and hot exhaust parts?
- Are all fuel connections tight?
- Has the fuel line(s) been secured at sufficiently close intervals to prevent chaffing and contact with sharp edges, electrical wiring, and hot exhaust parts?

7.2 Startup

⚠ WARNING

Batteries give off explosive gases that can cause severe personal injury. Do not smoke near batteries. Keep flames, sparks, pilot lights, switches, arc-producing equipment, and all other ignition sources away.

When all the items on the Installation Review check list have been checked, connect the battery cables to the battery, positive (+) cable first.

Read the Operator Manual and perform the maintenance and pre-start checks as instructed. The generator set is shipped from the factory with the proper level of engine oil, but the oil level should be checked before starting the generator set.

⚠ WARNING

This product incorporates a catalyst exhaust system which leads to subsequent higher exhaust gas temperatures and higher cooling air outlet temperatures. Due to these higher exhaust gas temperatures and higher cooling air outlet temperatures, the installer must review and follow all guidelines for the installation. Care must be taken to ensure that all installation requirements in this entire manual are met.

⚠ WARNING

EXHAUST GAS IS DEADLY! Do not operate the generator set when the vehicle is indoors or where exhaust can accumulate.

Start and operate the generator set, following all the instructions and safety precautions in the Operator Manual.

Check for fuel and exhaust leaks and unusual noises while the generator set is running under full and intermediate loads. Do not place the generator set in service until all fuel and exhaust leaks have been fixed and operation is satisfactory.

7.3 Hot Air Recirculation Test

⚠ WARNING

This product incorporates a catalyst exhaust system which leads to subsequent higher exhaust gas temperatures and higher cooling air outlet temperatures. Due to these higher exhaust gas temperatures and higher cooling air outlet temperatures, the installer must review and follow all guidelines for the installation. Care must be taken to ensure that all installation requirements in this entire manual are met.

A representative installation of the generator set must be tested to determine that the generator set will not overheat due to recirculation of hot air back into the generator set.

7.3.1 Test Method

⚠ WARNING

EXHAUST GAS IS DEADLY! Do not operate the generator set when the vehicle is parked indoors or where exhaust can accumulate.

1. Complete a representative installation.
2. Set up a load bank to run the generator set at rated full load.
3. Conduct the test at a location where the ambient air temperature will remain between 16 °C and 38 °C (60 °F and 100 °F).
4. Measure temperatures with thermocouples not heavier than 0.21 mm² (24 AWG).
 - a. Measure generator set inlet air temperature with one thermocouple tied in the middle of the inlet air grille.

- b. Measure ambient air temperature with a shielded thermocouple within 1.2 m (4 ft) of the generator set and approximately the same height. Make sure the thermocouple will not be affected by warm air discharged from the generator set or by sunlight. Use 50.8 mm (2 in) diameter white PVC piping at least 152.4 mm (6 in) long as a thermocouple shield.
- 5. Close all compartment doors and run the generator set at full load for at least an hour. Record temperatures at 15 minute intervals until they stabilize. Temperature is considered stable when there is no change in 3 consecutive readings. The following table illustrates how the data can be arranged for recording and analysis.

TABLE 8. TEMPERATURE DATA

THERMOCOUPLE LOCATION	TEMPERATURE °C (°F)				
	Time of Reading				
AMBIENT AIR					
INLET AIR					

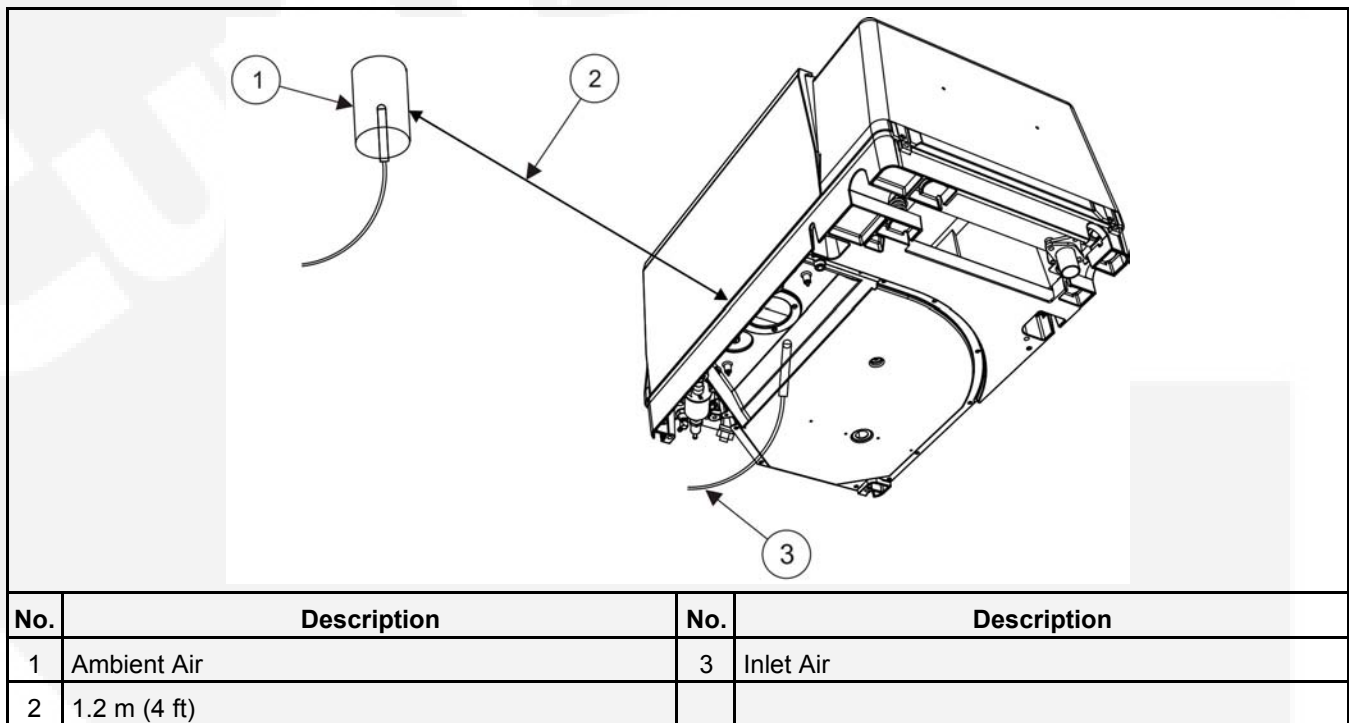

FIGURE 27. THERMOCOUPLE LOCATIONS FOR HOT AIR RECIRCULATION TEST

7.3.2 Test Requirement

⚠ CAUTION
<i>High ambient operating temperatures could reduce maximum generator set power output if the air temperature rise measured in this test is on the high end of the acceptable range.</i>

The rise in inlet air temperature over ambient air temperature must not exceed 8 °C (15 °F) in all modes of operation. A rise in inlet air temperature indicates hot air recirculation. If the rise exceeds the requirement, steps must be taken to reduce recirculation to an acceptable level.



Appendix A. Outline Drawings

Table of Contents

Figure 28. HGJAD/HGJAE Outline Drawing	59
--	----

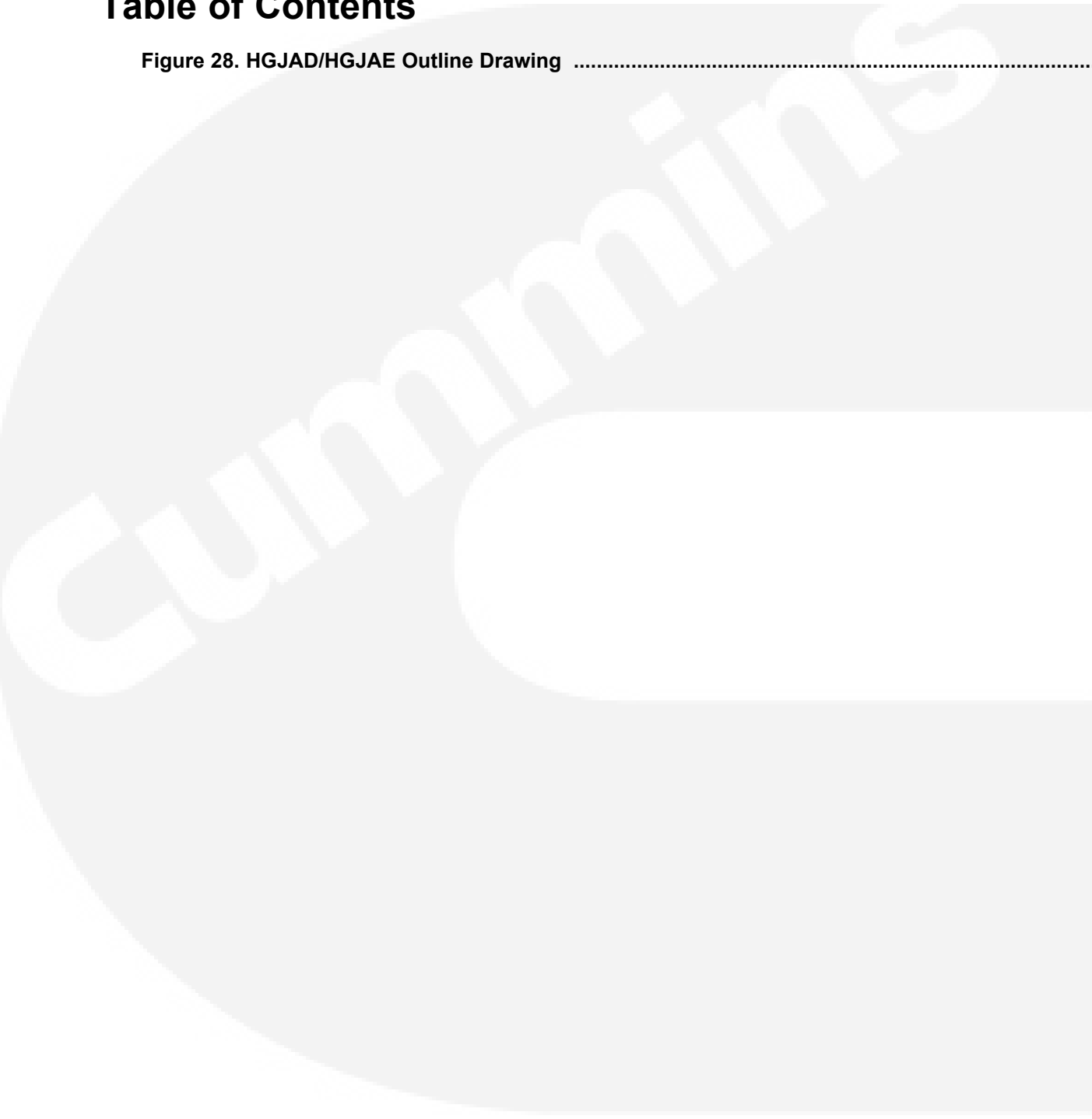



This page is intentionally blank.



A.0 HGJAD/HGJAE Outline Drawing

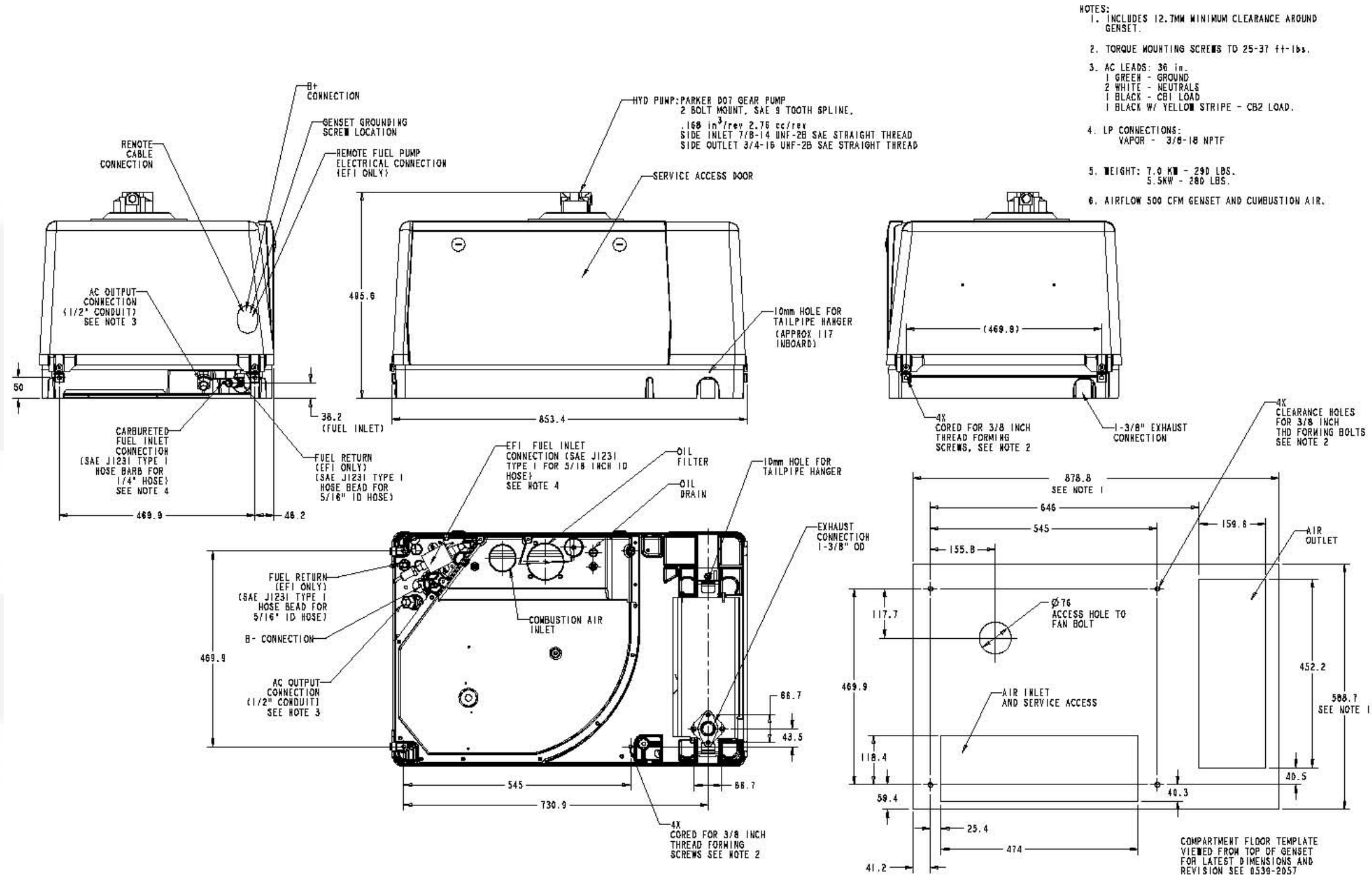

500-3449

FIGURE 28. HGJAD/HGJAE OUTLINE DRAWING

This page is intentionally blank.

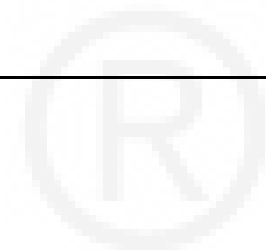

Cummins Power Generation
1400 73rd Ave. NE
Minneapolis, MN 55432 USA
Phone 1 763 574 5000
Toll-free 1 800 888 6626
Fax 1 763 574 5298

Copyright © 2014 Cummins Power Generation, Inc. All rights reserved.
Cummins, Onan, the "C" logo, and "Performance you rely on." are
trademarks of Cummins Inc.

